

生活中有趣的物理 演示實驗

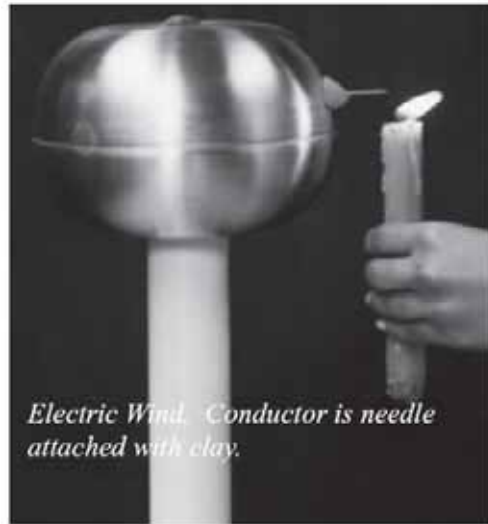

走進清華科學殿堂
快樂玩物理、探究竟



清華大學物理系
普通物理實驗室



演示教學目錄

- 一、力學篇
- 二、波動篇
- 三、熱力篇
- 四、電學篇
- 五、磁學篇
- 六、光學篇
- 七、能源篇

一、力學篇

- 氣墊船(Hovercraft)力學體驗運動(兩套)
- 一維動力台車(1D Kinesthetics Cart)體驗運動
- 二維動力台車(2D Kinesthetics Cart)體驗運動
- 雲霄飛車 (Complete Roller Coaster)實驗-圓周運動、離心力
- 離心軌道-重力位能和旋轉動能之能量轉換
- 麥斯威爾飛輪(Maxwell Wheel)-能量轉換
- 雙珠競走--走捷徑比較快？
- 投射撞擊百發百中實驗-自由落體&拋體運動
- 由低處滾往高處滾動的雙錐體-重心問題
- 角動量守恆的親身體驗-飛輪與旋轉椅的相對旋轉運動
- 空氣砲彈(Air Cannon)-氣渦流力
- 鐵鍊栓環喜結良緣(Make a good match)

二、熱力學篇

- 伽利略溫度計(Galileo Thermometer)
- 不停地喝水的鳥(Thermodynamic drinking bird)
- 熱動力沸騰器(Thermodynamic Boiler)-液氣相轉變示範實驗
- Hand Bubbler Boiler Pen Demonstrates Energy Transfer
- 輻射計(Radiometer)-光熱轉輪
- 咖啡杯上的史特林引擎(Stirling engine)
- 翅膀揮舞的蝴蝶-是熱縮冷脹嗎?
- 紫外光偵測珠(Ultraviolet Detecting Beads)
- 太陽能袋World's Largest Solar Bag

六、光學篇

- **Ghostly Optical Illusion**-看得到卻捉不著的影像光學
反射鏡組
- 偏振(極)片(Polarizing Sheets)--光消失了，影像也就
看不見了!
- 掌上簡易光譜儀-使用光柵片製作簡易的光譜儀
- 物理學防偽技術
- 旋轉紙陀螺--將黑白變七彩!
- 折光潛影-偽鈔辨識、雙影像、動畫、、應用
- 具放大鏡功能之輕便可撓的塑膠放大片
- Morie Patterns
- Euler's disk

七、能源篇

- 太陽能發電
- 風力發電
- 太陽能與風力混合發電
- 氫燃料電池
- 火力發電模型
- V8引擎模型

一、力學篇

- 氣墊船(Hovercraft)力學體驗運動(兩套)
- 一維動力台車(1D Kinesthetics Cart)體驗運動
- 二維動力台車(2D Kinesthetics Cart)體驗運動
- 雲霄飛車 (Complete Roller Coaster)實驗-圓周運動、離心力
- 離心軌道-重力位能和旋轉動能之能量轉換
- 麥斯威爾飛輪(Maxwell Wheel)-能量轉換
- 雙珠競走--走捷徑比較快？
- 投射撞擊百發百中實驗-自由落體&拋體運動
- 由低處滾往高處滾動的雙錐體-重心問題
- 角動量守恆的親身體驗-飛輪與旋轉椅的相對旋轉運動
- 空氣砲彈(Air Cannon)-氣渦流力
- 鐵鍊栓環喜結良緣(Make a good match)

氣墊魔毯(Hovercraft)力學體驗運動

- The Hovercraft is designed to help students experience frictionless motion, thus better understand Newton's Laws.
- Its large platform provides enough area for the rider to comfortably sit while riding.
- The durable Nylon skirt will withstand the rigors of the classroom environment.
- The optional Cordless Air Source is a convenient way supply air to the Hovercraft, however most vacuums/blowers used in a wood shop will also be sufficient to lift the Hovercraft.



- [Movie file](#)
- [Manual](#)



一維動力台車 (1D Kinesthetics Cart) 體驗實驗



-PASCO SE8747



Key Features

- The Student "Becomes" the Dynamics Cart
- Experience the Feel of Physics Concepts

When a student sits on top of the Kinesthetics Cart, he or she actually becomes part of the experiment.

Active involvement makes for "fun physics," but, more importantly, it provides a sensory experience, or "kinesthesia," that teaches what a concept such as Newton's First Law "feels like."

Students' common misconceptions are quickly eradicated.

The experience is retained in "muscle memory" and helps the student understand and remember the concepts.

一維動力台車 (1D Kinesthetics Cart)



-PASCO SE8747

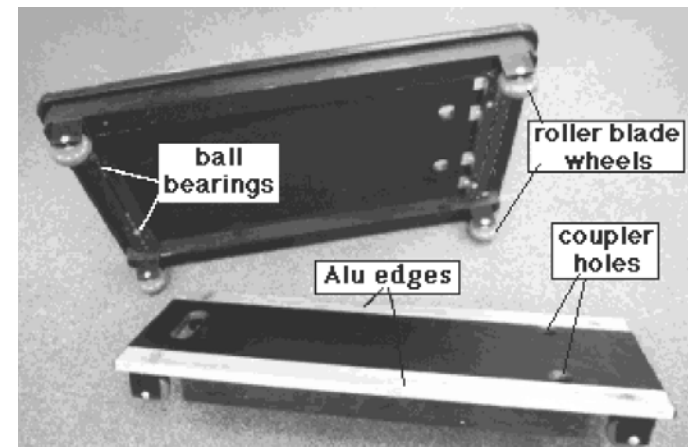
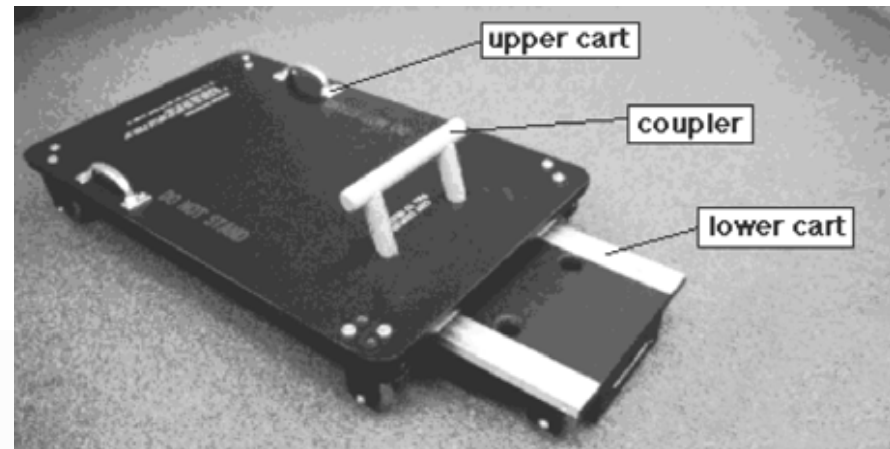

Features:

1. Ball bearings mounted on the bottom of the upper cart allow it to slide off the lower cart
2. Low "Roller Blade" Wheels on both carts allow for smooth, constant travel
3. Coupler keeps carts piggy-backed until rider removes it
4. Cart length of 90.5 cm

Typical Experiments of 1D Kinesthetics Cart

1. Newton's First Law
2. Newton's First Law
3. Newton's Second Law
4. Newton's Second Law
5. Coin-toss Misconception Demo*
6. Projectile Motion*
7. Uniform *vs.* Accelerated Motion*
8. Newton's Third Law
9. Center of Mass -- The Boardwalk*
10. Simple Harmonic Oscillator*
11. Human Oscilloscope*
12. Collisions: Newton's Third Law
13. Newton's Third Law Misconceptions
14. Newton's Third Law Misconceptions
15. Newton's Third Law Misconceptions



Experimental Manual

*These experiments require additional equipment not included with the Kinesthetics Cart.

Sample: Experiment 1 - Newton's First Law Demonstration

1. One rides on the piggy-backed carts at initial velocity, V_o . He removes the coupler as he approaches the block fastened to the floor.
2. The lower cart strikes the block and stops, but the upper cart and student continue to move forward at velocity, V_o .
3. The slight jolt that the student feels when the wheels hit the floor will help ingrain Newton's First Law in the student's memory.
4. **Newton's First Law:** An object in motion continues in motion, unless acted upon by an external force.

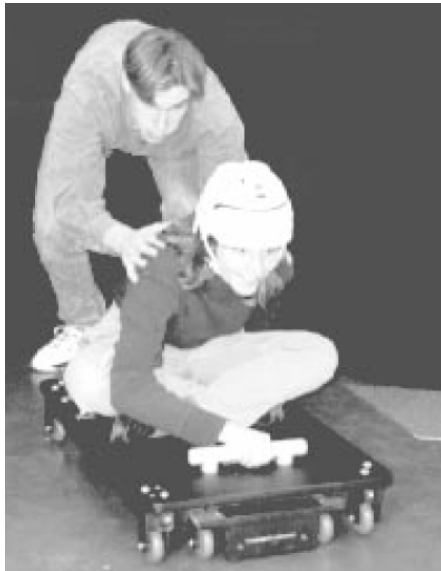

Experiment 6

-Independence of the X and Y Motion of a Projectile

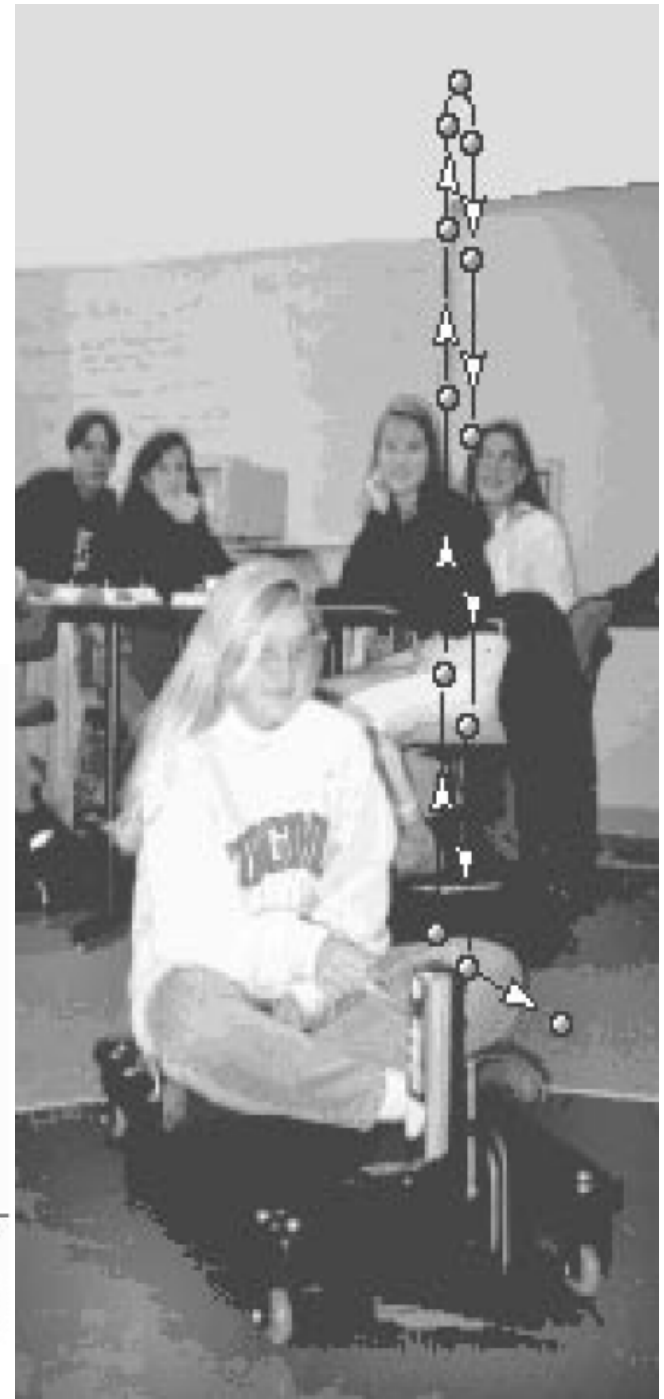
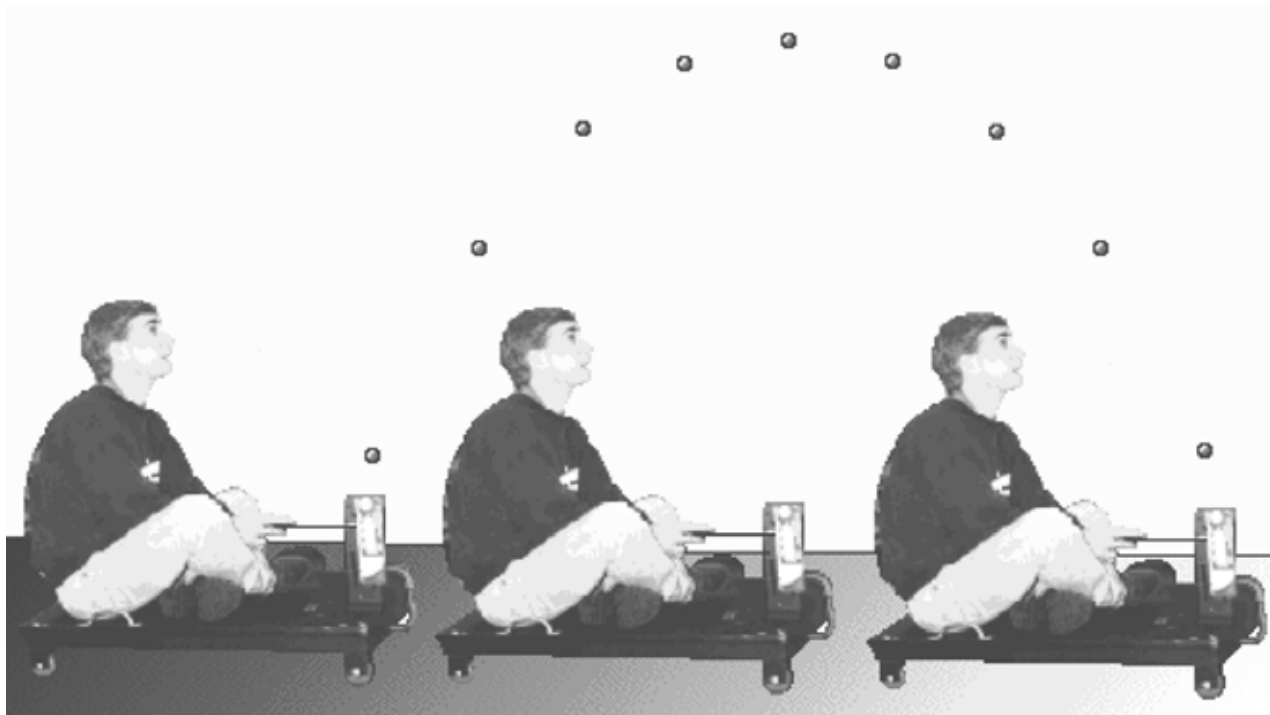

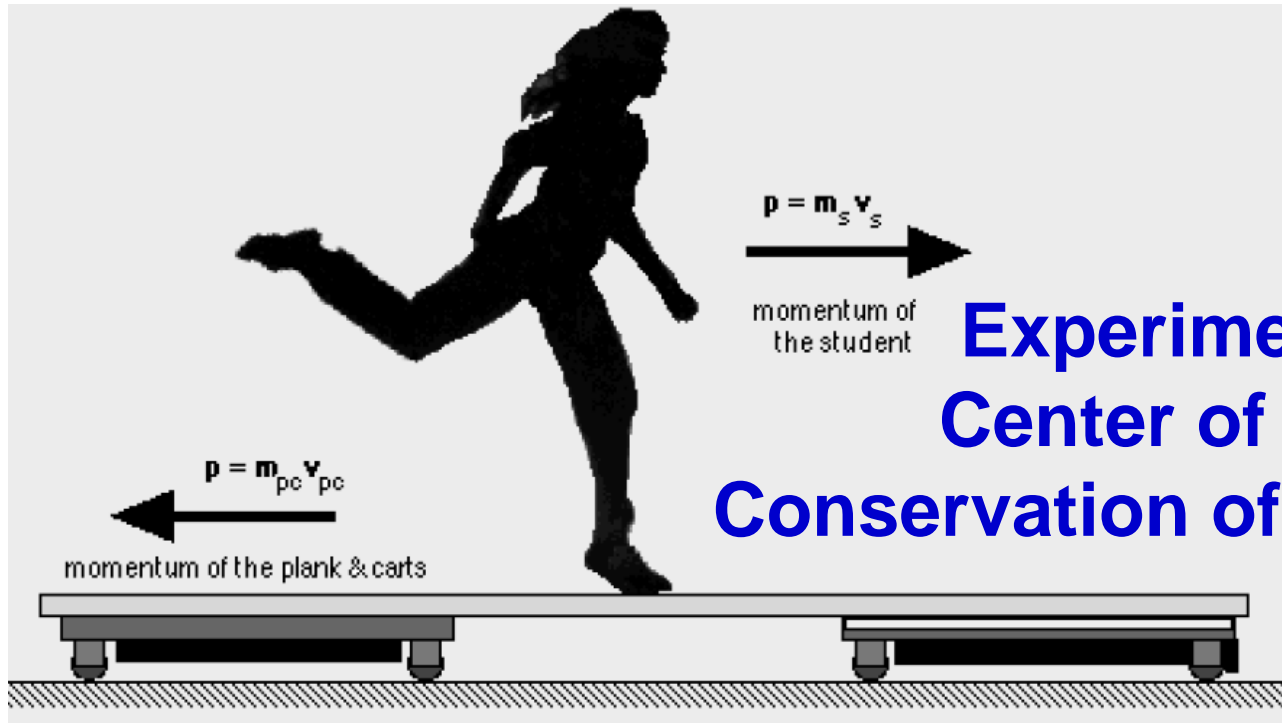

Experiment 9: Center of Mass Conservation of Momentum

Newton's Third Law- "A Crushing Experience"

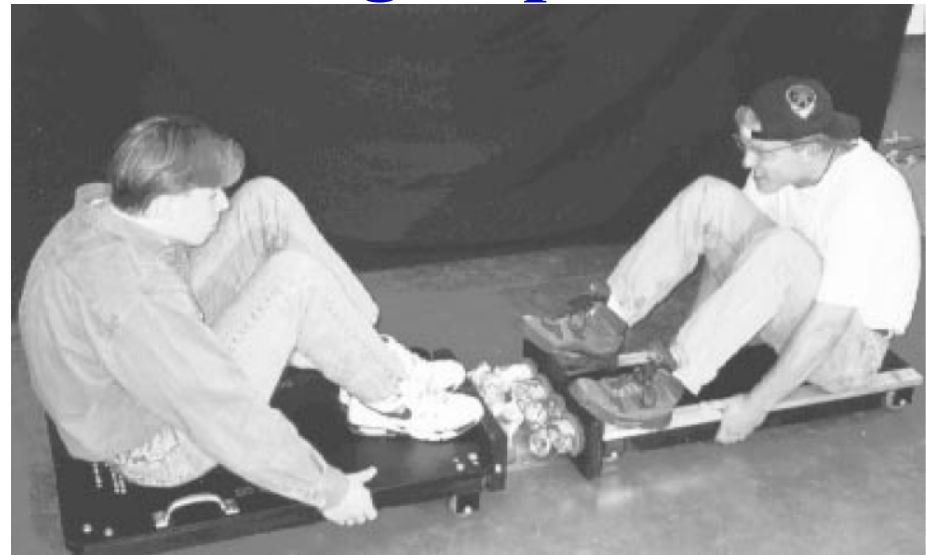

Experiment 6a: Independence of the X and Y Motion of a Projectile

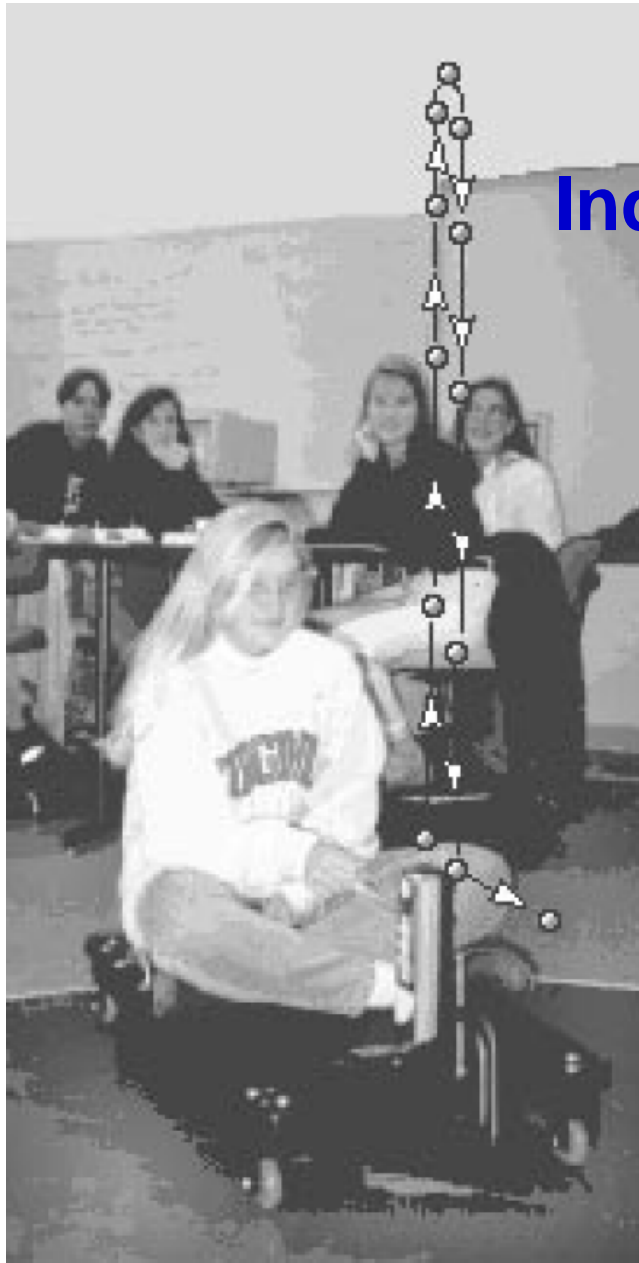
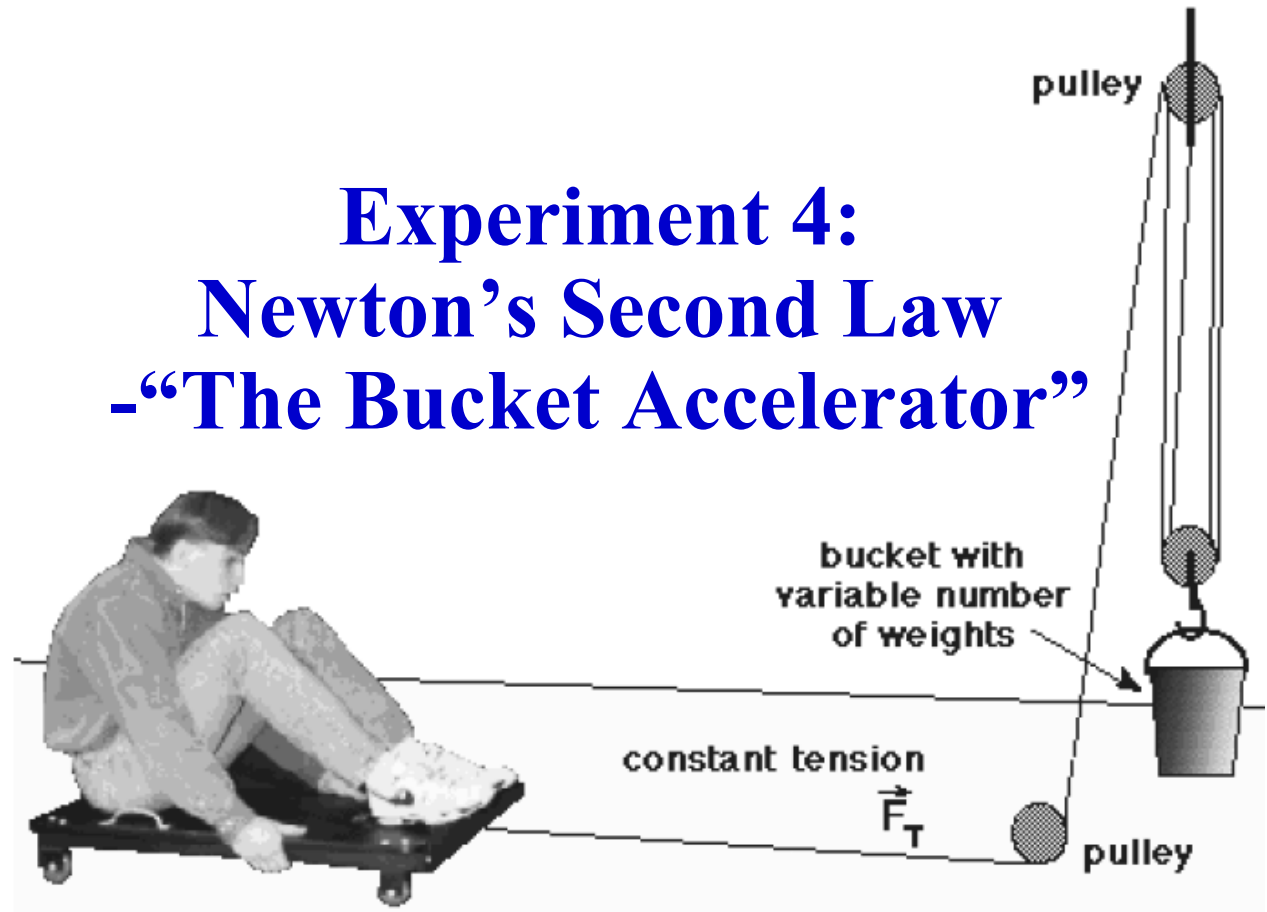

Fig. 6-1: A ball is launched vertically from a stationary cart (stationary observer).

Experiment 4: Newton's Second Law -“The Bucket Accelerator”



二維動力台車(2D Kinesthetics Cart)

力學體驗運動

- With this circular, 6-wheeled cart, students can "feel" the forces and accelerations that occur during two-dimensional motion such as circular and trajectory motion. This cart enables students to directly experience centripetal force, and it allows quantitative verification of the relationship between centripetal force, orbital period and the radius. As they sit on the cart, students will finally be convinced that centripetal force is directed radially inward.
- Manual-2D KINESTHETICS CART



The Foucault Pendulum Demonstration

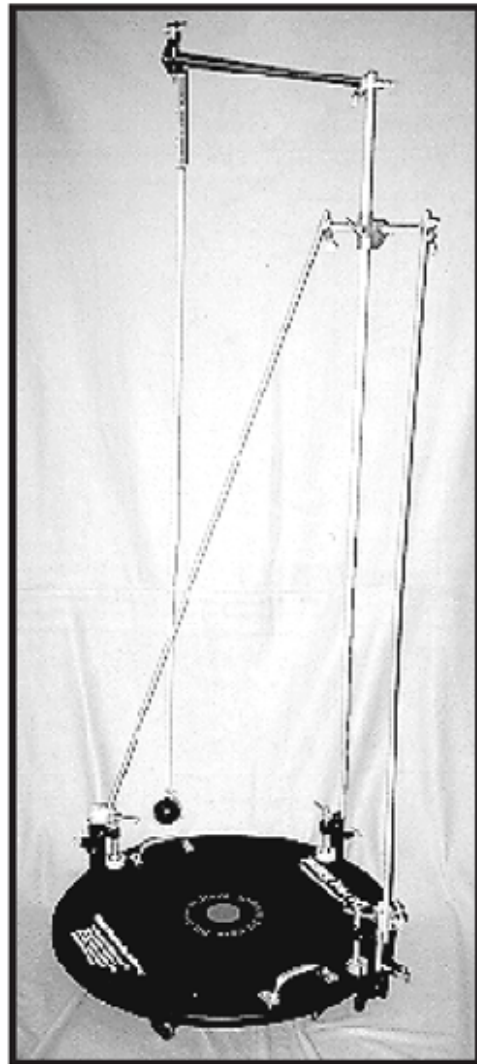

The Foucault
Pendulum in action.

In the rotating frame of the rider, the plane of the pendulum rotates, although in the lab frame its plane of oscillation remains fixed.



雲霄飛車實驗 (Complete Roller Coaster)

The Roller Coaster including the track and Mini Cars and some accessories allows the quantitative study of energy and motion.

Key Features:

1. 3-Car Roller Coaster
2. Quantitative Studies of Energy Conservation
3. Easy to Change Track Configurations

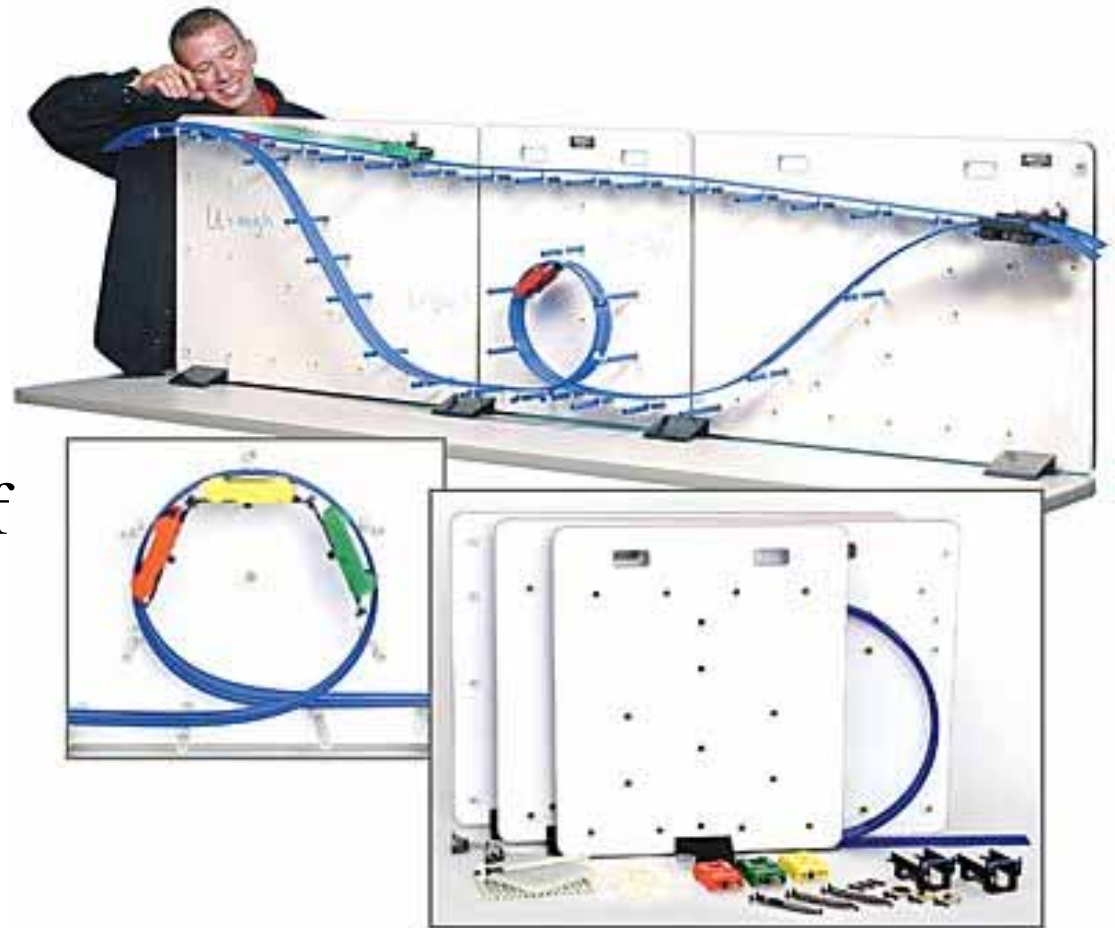

雲霄飛車實驗(Complete Roller Coaster)

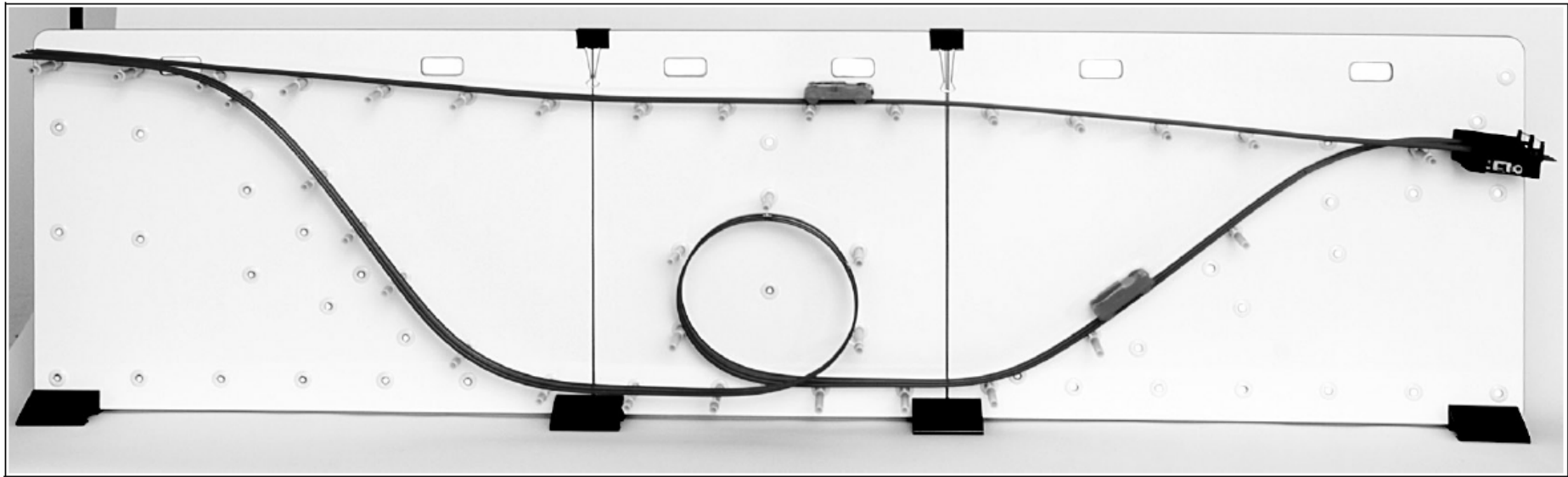

Typical Applications:

- 1. Conservation of Energy**-Release the Mini Car and measure its velocity and height at several points along the track. Use these values to calculate total energy of the Mini Car. Frictional losses are less than 5%.
- 2. Constant Acceleration**-Several straight inclined sections can be used to measure and demonstrate constantly accelerated motion.
- 3. Projectile Motion/Conservation of Energy** -- Use the initial height of the Mini Car to determine its speed as it flies off the end of the track. Using this speed and height above the ground when it leaves the track, predict where the Mini Car will land.

- 將裝有一小重物的塑膠燒杯置放於滑車上，使滑車從含有圓形軌道的最左側軌道上滑落下，觀察滑車在整個軌道上的運動情形。



雙珠競走--走捷徑比較快？

- 目的：展現運動物體的速度與加速度間的關係、向量分解。
- 實驗：演示示範影片
 1. 初始速度相同的兩個球在具相同水平位置的起點和終點，但路徑不同的軌道上競走。其中一球不受加速度影響，另一球軌道於鉛直面上高度先下降後再上升。
 2. 將兩球放置在發射架上，以磁控開關使兩球的發射條件和初始的運動速率相同。將球發射，觀察哪一顆球先抵達終點。
- 思考問題
 1. 兩球最終速度是否相同？
 2. 較快抵達終點是否意味過程中獲得能量？這些能量從何而來？
 3. 兩球的時間差與什麼條件相關？
 4. 下降的球不論多深都回得來？
 5. 加入球轉動的情形將會如何？
 6. 加入摩擦力考慮，結果如何？



討 論

1. 兩球最終速度是否相同？
2. 比較快抵達終點是否意味過程中獲得能量？
這些能量從何而來？
3. 兩球的時間差與什麼條件相關？
4. 下降的球不論多深都回得來？
5. 加入球轉動的情形將會如何？
6. 加入摩擦力考慮，結果如何？

離心軌道

- 為何小鋼球不會從軌道的頂端掉下？而改變軌道的角度，還可以示範其他的拋體運動。本組包含鋁製圓周軌道、小鋼球及木製底座。



投射撞擊--百發百中實驗

- **Experiment 1: Projectile Motion**

- The purpose of this experiment is to predict and verify the range of a ball launched at an angle.
- The initial velocity of the ball is determined by shooting it horizontally and measuring the range and the height of the Launcher.

1. 使發射器中的小鋼球對準另將作自由落體運動的物體發射做拋體運動。
2. 調整發射方向於兩球在一連線上。
3. 發射小鋼球，觀察兩球相碰撞之點。
4. 調整拋體的發射仰角和被射物體的高度，重新觀察兩球相碰撞的情形。

演示影片：[投射撞擊1](#), [2](#), [3](#), [4](#)

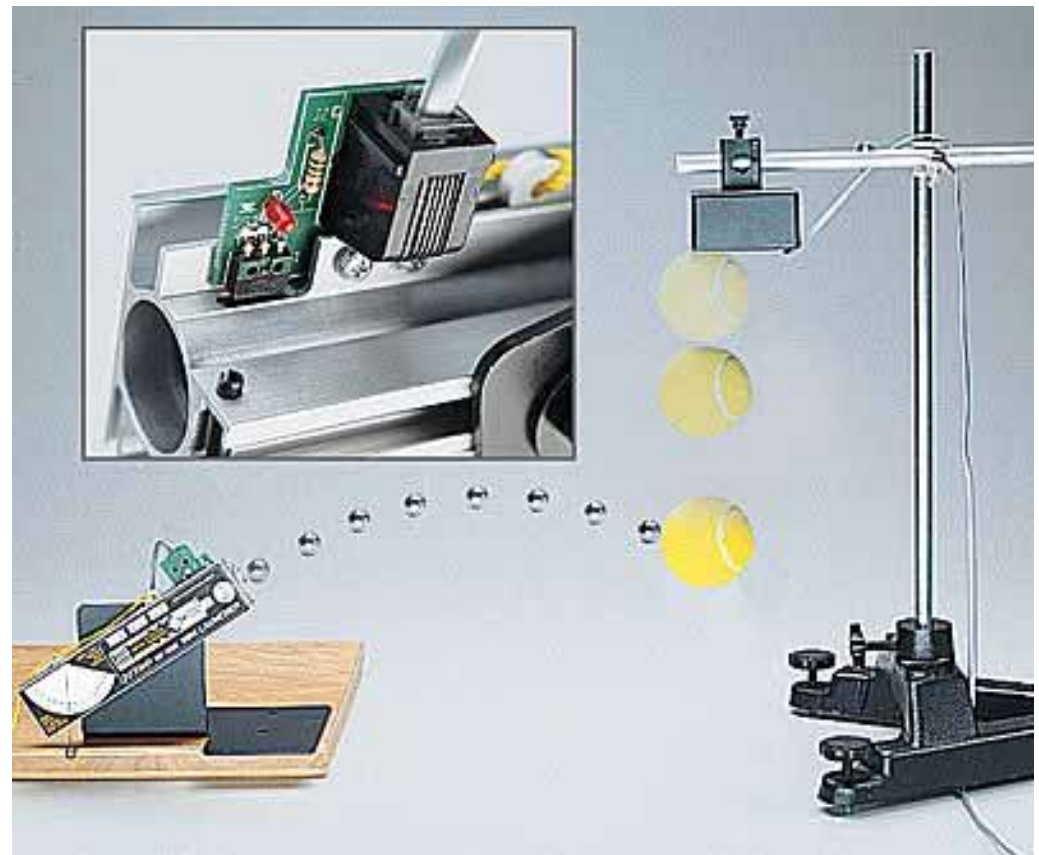

由低處滾往高處滾動 的雙錐體

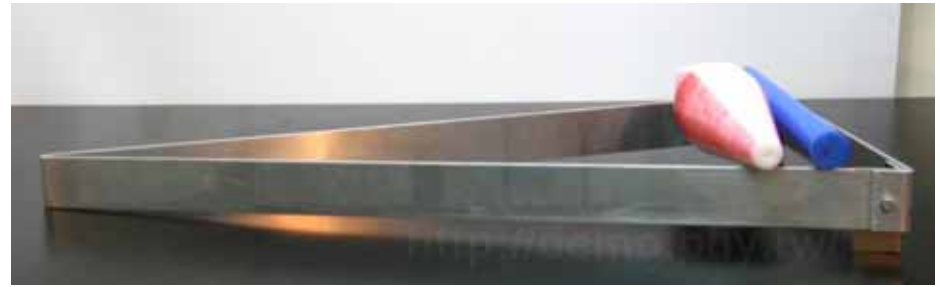

目的：觀察物體的重心與滾動運動間的關係。

實驗：

1. 兩個圓錐底面連結在一起形成一個雙錐體。
2. 一個V字型的軌道，使V字型尖端的部分低於另一端。
3. 將雙錐體橫跨放置於V型軌道上較低的一端，觀察雙錐體滾動的方向。

示範影片：<http://demo.phy.tw/experiment/dynamics/double-cone/>

原理思考

1. 雙錐體為何會由低處往高處的方向滾動？
2. 雙錐體的錐角、V型軌道的張角與軌道面的斜度對本物體的滾動方向有何影響？

Double Cone rolls upward on a plane

- **Demonstration: Ascending Cone**-Defy gravity as our cone appears to roll upward.
- This visual demonstrator of the center of gravity consists of a wooden frame with diverging rails and a double-ended cone.
- The cone appears to roll upward; in actuality, it is the center of mass that is moving downward.

The physical explanation:

(a) **The center of mass of the cone is descending.**

(b) The motion may be described by the energy conservation law for the cone-Earth as follows:

$$(1/2)mv^2 + (1/2)I\omega^2 + mgw = \text{constant}$$

$I = (3/5)mR^2$ = rotational inertia of double cone
with respect to symmetry axis

Where m = mass (g), R = radius (cm), v = velocity (m/s²) and ω = angular velocity (rad/s), w = instantaneous height of center of mass of double cone over zero level of potential energy.

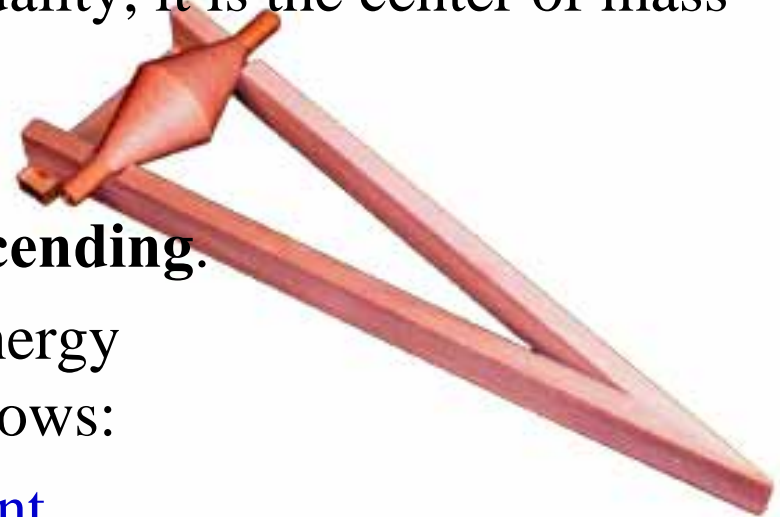

問題討論

1. 比較一般圓柱或輪子在斜面上的滾動與本實驗有何不同？
2. 雙錐錐角大、軌道開角大、軌道斜角小是向上滾的條件嗎？
3. 如果沒有摩擦力，結果會如何？
4. 雙錐爬到何處會停止？會再滾回來？
5. 若雙錐中的一錐為空心，一錐為實心，結果如何？
6. 如果雙錐以尖端部分相連結來做實驗，結果如何？

延伸實驗：可以將兩個塑膠漏斗開口部分用膠帶黏住，以筷子做軌道架，在書本上做本實驗。

角動量守恆的親身體驗

- 飛輪與旋轉椅間的相對旋轉運動

目的：體驗角動量變化的效果。

實驗裝置：活動轉椅，飛輪和電鑽。

1. 演示者坐在活動轉椅上，手持飛輪。
2. 另一位同學以手或電鑽讓飛輪快速轉動，演示者變動飛輪面的方位，觀察演示者座椅的轉動和飛輪轉動間的相對變化情形。

演示影片一、二

原理思考

1. 當演示者將飛輪軸順時針方向旋轉時，
旋椅轉動方向為何？
2. 當演示者將飛輪軸逆時針方向旋轉時，
旋椅轉動方向為何？



- 討論

演示者先感受到雙手轉變飛輪軸時傳回來一股扭力，他為了維持坐姿，雙腿會用力因而帶動座椅旋轉。

- 關於實驗與

1. 座椅必須非常滑順，摩擦力越小時的效果越佳。
2. 飛輪直徑越大而且重量越重時，效果越好。

- 實驗注意事項

操作時注意演示者的安全，飛輪脫手或演示者摔倒都容易造成受傷。演示助教必須要有豐富的操作經驗才能上場。

Maxwell Wheel

- [Refer ppt file](#)
- Useful for demonstrating momentum, conservation of energy and torque, this apparatus is basically a large metal flywheel suspended by two strong cords in a metal frame.
- The cords are wound around the shaft of the wheel which is then released. The wheel will unwind as it falls but will wind itself back up as the momentum carries it upward in the opposite direction.
- This oscillation process will continue for several moments before gradually coming to a stop as the wheel slowly loses momentum and travels less each time.



Air Cannon (空氣砲彈) or Airsooka Air Gun

-A great demonstration of the energy that can be stored in waves.

- The Air Cannon uses a **vortex of air** for ammunition.
- Its unique shape creates a **stable toroidal vortex**. Pull back the flexible membrane, release and the invisible wave front of air can hit a target 20 feet away!



Airzooka air gun

- Launch a full air assault without ever leaving the ground with the 'Airzooka air gun'.
- Airzooka is a hand held fun gun that fires a ball of air with enough power to mess up a persons hair, ruffle their shirt or scatter papers from a distance of 20 feet away.
- By pulling back the membrane and releasing - a shock wave of air is sent hurtling at your target.
- Requiring no batteries or electricity, Airzooka works with an elasticated air launcher.
- Pull back and release the launcher like a catapult, firing the ball of air out of the air gun.
- Because it shoots air, you never run out of ammo!



The Vapor Ring structure is called a "Toroidal Vortex".
 Toroidal = doughnut shaped
 Vortex = whirling or circular motion of a liquid or air, tending to form a low pressure area in the center.
 Tomadoes, hurricanes, and whirlpools are naturally occurring vortices.

Vapor-Ring Physics

QUESTION; How does The Vapor-Ring (TOROID) move forward?
 Think of the cross-section of rotating air in the Vapor-Ring like the tire on a tractor moving over the ground. The friction of the rotating air on the outside surface of the Vapor-Ring against the surrounding stationary air makes the ring tractor through the air. There is an overall circular flow of air. Pressure is not created in front of the Vortex. The Vapor in the Vortex makes it appear that air is moving from left to right. The backward flow of air cancels out the forward flow of air.

Air flow is slowed at edge of opening causing a vortex to form with the fast moving air through the center ("Coanda effect")

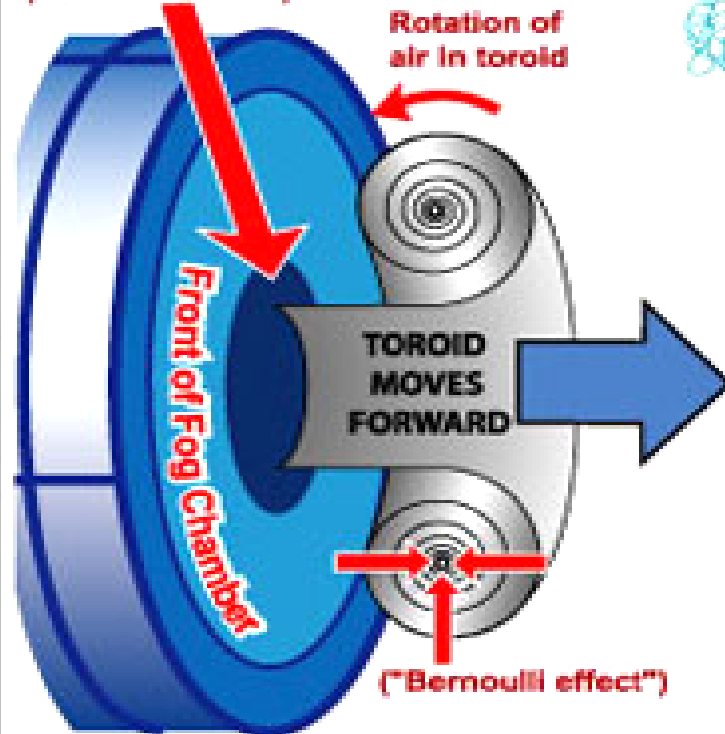

Low pressure at center of Toroidal Vortex holds Vapor around center of ring

stationary air creates friction against the rotating air in the vapor-ring

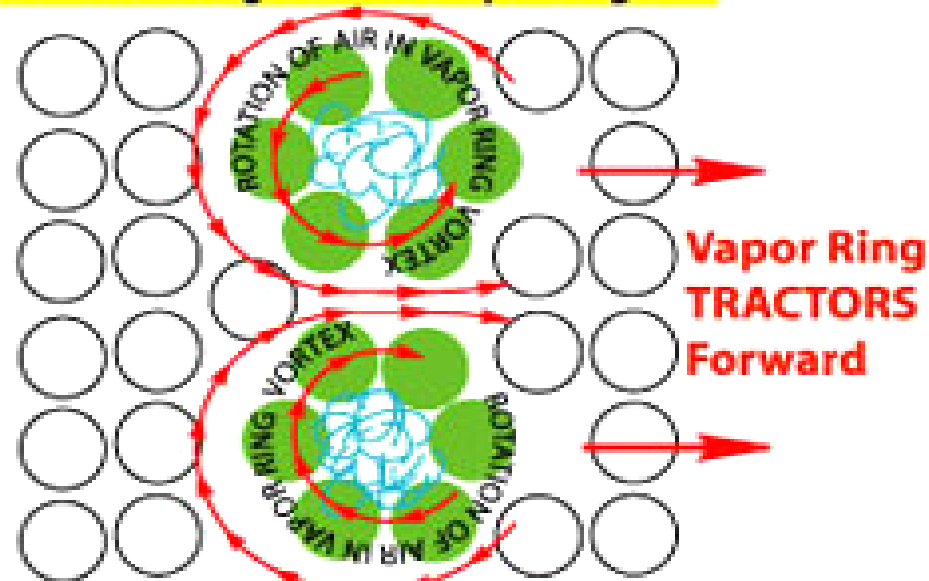

Air friction makes the Vapor-Ring grow larger in diameter and pulls Vapor away from the ring as it moves forward.

喜結良緣(鐵鍊栓環, Make a good match)

步驟一：用右手大拇指和食指撐起鐵鍊，中指放於大拇指與食指正下方緊靠手心。

步驟二：將鐵環套於鐵鍊中間，再往上提至右手中指上方，將鐵環一端放於中指上(拇指食指下)。

Step 1: Use your thumb and forefinger to support the chain in the center of the ring. At the same time, your middle finger is close to your thumb.

Step 2: Let the ring lean against your middle finger loose the ring, then the ring will be hitched by the chain.

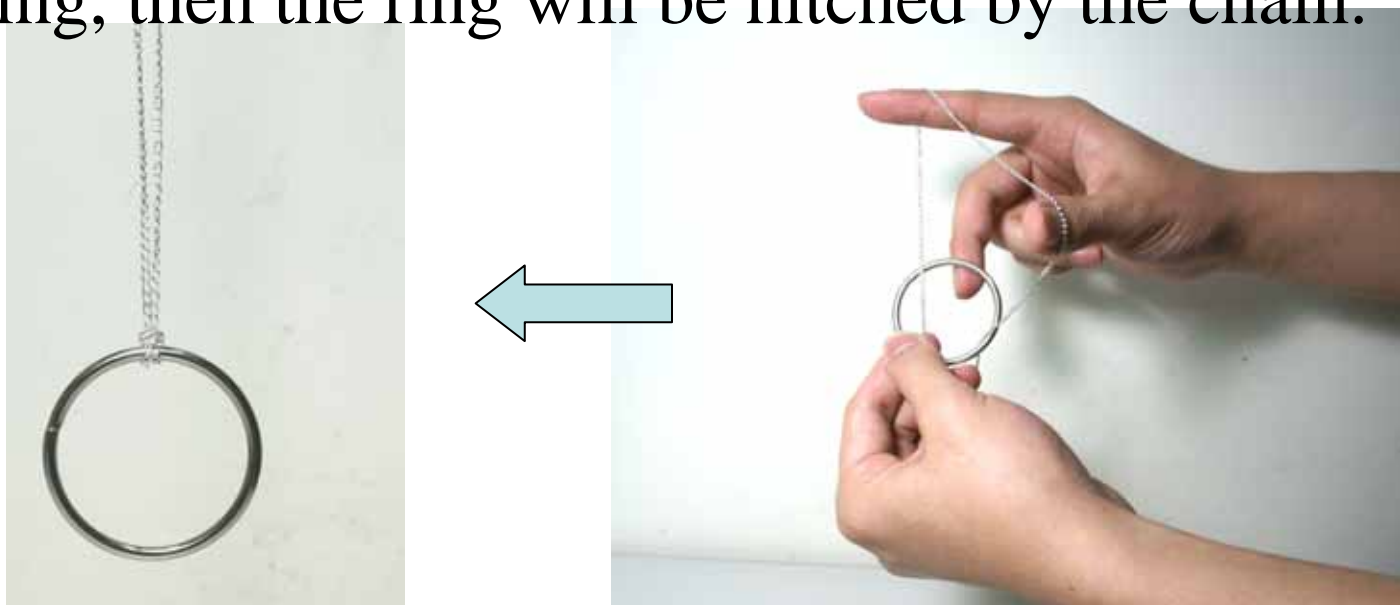

二、熱力學篇

- 伽利略溫度計(Galileo Thermometer)
- 不停地喝水的鳥(Thermodynamic drinking bird)
- 熱動力沸騰器(Thermodynamic Boiler)-液氣相轉變示範實驗
- Hand Bubbler Boiler Pen Demonstrates Energy Transfer
- 輻射計(Radiometer)-光熱轉輪
- 咖啡杯上的史特林引擎(Stirling engine)
- 翅膀揮舞的蝴蝶-是熱縮冷脹嗎?
- 紫外光偵測珠(Ultraviolet Detecting Beads)
- 太陽能袋World's Largest Solar Bag

Galileo Thermometer (伽利略溫度計)

Be invented by Galileo Galilei four centuries ago
To indicate the approximate current temperature.



How does a Galileo thermometer work?

- Based on a thermoscope invented by Galileo Galilei in the early 1600s.
 - ⇒ A simple, fairly accurate thermometer, today it is mostly used as decoration.
- Be consisted of a sealed glass tube that is filled with water and several floating bubbles.
- ✓ The bubbles are glass spheres filled with a colored liquid mixture. This liquid mixture may contain alcohol, or it might simply be water with food coloring.
- ✓ Attached to each bubble is a little metal tag that indicates a temperature. A number and degree symbol are engraved in the tag.



- **These metal tags are actually calibrated counterweights.**

The weight of each tag is slightly different from the others.

- ✓ Since the bubbles are all hand-blown glass, they aren't exactly the same size and shape. **The bubbles are calibrated by adding a certain amount of fluid to them so that they have the exact same density.**
- ✓ So, after the weighted tags are attached to the bubbles, each differs very slightly in density (the ratio of mass to volume) from the other bubbles, and the density of all of them is very close to the density of the surrounding water.

- An object immersed in a fluid experiences two major forces: **the downward pull of gravity and the upward push of buoyancy.** It is the downward force of gravity that makes this thermometer work.
- The basic idea is that as the temperature of the air outside the thermometer changes, so does the temperature of the water surrounding the bubbles.
- As the temperature of the water changes, it either expands or contracts, thereby changing its density. So, at any given density, some of the bubbles will float and others will sink.
- **The bubble that sinks the most indicates the approximate current temperature.**



Galileo thermometer

- Consider the example: Let's say there are five bubbles in the thermometer:

1. A blue bubble represents 60°F
2. A yellow bubble represents 65°F
3. A green bubble represents 70°F
4. A purple bubble represents 75°F
5. A red bubble represents 80°F

- The blue bubble (60°F) is the heaviest (densest) bubble, and
- each bubble thereafter is slightly lighter, with the red bubble being the lightest.
- Now, let's say the temperature in the room is 70°F.
- Since the surrounding air is 70°F, we know the water inside the thermometer is also about 70°F. The blue and yellow bubbles (60 and 65°F, respectively) are calibrated so that they have higher densities than the water at this temperature, so they sink.
- The purple and red bubbles each have a density that is lower than the surrounding water, so they float at the very top of the thermometer. Since the green bubble is calibrated to represent 70°F, the same temperature as the water, it sinks slightly so that it is floating just below the purple and red bubbles -- thereby indicating the room's temperature!



Solution

- A Galileo thermometer combines [Archimedes' principle](#) with the fact that [liquids generally expand faster](#) with increasing temperature than solids do.
- Each sphere in the thermometer has [an average density \(a mass divided by volume\)](#) that is very close to that of the fluid in the thermometer.
- As stated in Archimedes' principle, if the sphere's average density is less than that of the fluid, the sphere floats and if the sphere's average density is more than that of the fluid, it sinks.
- But the fluid's density changes relatively quickly with temperature, becoming less with each additional degree.
- Thus as the temperature of the thermometer rises, the spheres have more and more trouble floating.
- Each sphere's density is carefully adjusted so that it begins to sink as soon as the thermometer's temperature exceeds a certain value.
- At that value, the expanding fluid's density becomes less than the average density of the sphere and the sphere no longer floats.
- The spheres also expand with increasing temperature, but not as much as the fluid.
- Here is a picture of a combined Galileo thermometer and [simple barometer](#).
- In addition to measuring the temperature with floating spheres, this device measures the outside air pressure with a column of dark liquid.
- It has a trapped volume of air that pushes the liquid (visible at the bottom of the unit) up a vertical pipe when the outside air pressure drops.

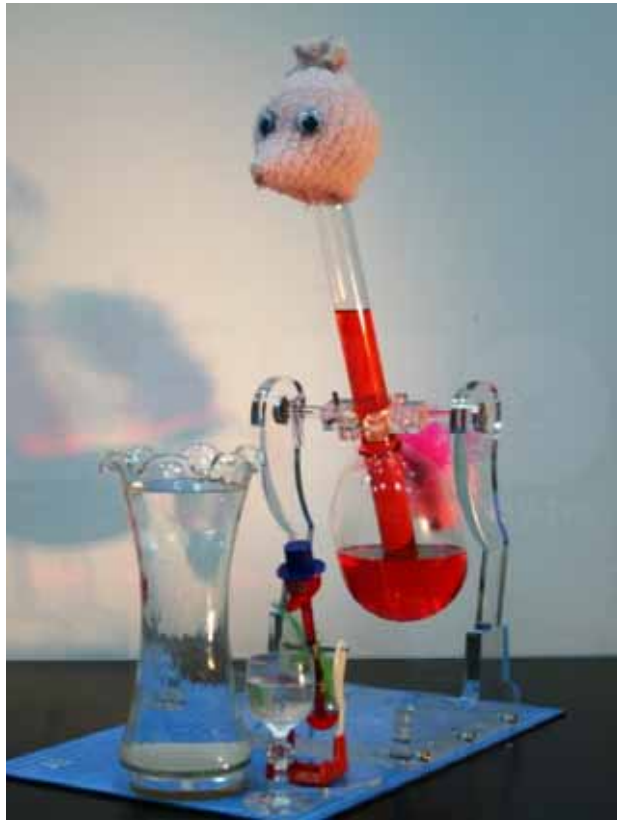

喝水不停的熱力學鳥



⇒一開始喝水，就喝個不停的鴨子

鴨子喝水是常見的科學玩具，仔細觀察裝置的結構及操作過程，思考其原理。

實驗：將鴨子的頭部(嘴喙)浸入水中後放手，鴨子回到平衡位置附近搖搖晃晃。不久後，又開始自動將頭部浸入水中，繼續喝水。鴨子一旦開始喝水，就會重複喝水的動作。如此過程可以不斷重複。

- 一個熱能與機械能互相轉換的熱力學過程。
- The dunking is due to the evaporating water, which cools the head reducing the pressure of the gas inside. The liquid inside the bird rises up from his tail towards his head, causing the bird to tip and appear to be drinking. As the bird dunks, the liquid returns to its tail, and the process begins again.

原理探討

- 鴨子喝水其實是個熱力學過程，是將熱能轉為機械能的過程。為什麼可以這麼說？我們先作以下的觀察和思考：
 1. 鴨子的頭和身體分別是玻璃球，透過一根玻璃管連接。
 2. 將頭部浸入水中時，內部液體怎麼流動？
 3. 頭部濕了以後，溫度會下降還是上升？會怎麼影響氣體的壓力？
 4. 頭部浸水後放手，是什麼讓鴨子回到直立的狀態(進而搖晃)？鴨子的重心在哪裡？會因為液體的流動而改變嗎？
 5. 搖搖晃晃的過程有什麼作用？
 6. 鴨子的頭部(嘴喙)是什麼材質？會影響結果嗎？
 7. 內部液體是特殊的嗎？有什麼性質？水可以嗎？
 8. ” (二氯甲烷), “ether” (乙醚) 等。



● 進一步問題探討

1. 環境的濕度會影響鴨子重複喝水的頻率嗎？
2. 水杯裡的水溫會影響鴨子重複喝水的頻率嗎？水冷些或熱些的影響是什麼？
3. 鴨子可以重複喝水的動作，能量是哪裡來的？有沒有違背能量守恆定律？一般的單擺在擺動一段時間後也終會因為摩擦力而停止，為什麼鴨子不會？我們的確看到當鴨子搖晃的程度漸漸變小後，不一會兒怎麼又「自動」將頭伸入水中。這「神奇」的能量是哪裡來的？

Thermodynamic Drinking Bird

- The 'Drinking Bird' is disguised as a great demonstration of thermodynamics.
- When the head of the bird is moistened with water it will repeatedly tip over and appear to be drinking from a cup placed in front of it.
 - The dunking is due to the evaporating water, which cools the head reducing the pressure of the gas inside. The liquid inside the bird rises up from his tail towards his head, causing the bird to tip and appear to be drinking. As the bird dunks, the liquid returns to its tail, and the process begins again.
 - In essence this is a small, cleverly designed thermodynamic engine which only needs water to run!
 - Avoid breaking glass, contains methylene chloride (二氯甲烷) and may stain clothing and other surfaces.
 - ✓ Do not swallow or allow to come into contact with eyes. Flammable. Keep away from flame and other heat sources. CHOKING HAZARD:



- **Setup:** Wet cloth which covers the tube in the bird (i.e. wet bird's head) and set up the bird with a beaker in front of it. The gas in the birds, which consists of various organic fluids, will condense causing the birds to "drink". **The water cools and reverses the condensation process** and the bird settles back down.
- **Concepts Displayed: condensation, expansion, Rankine cycle**
- [Click Here to see a short videoclip of the demonstration.](#)
- [Click here for a more detailed explanation of how it works](#)

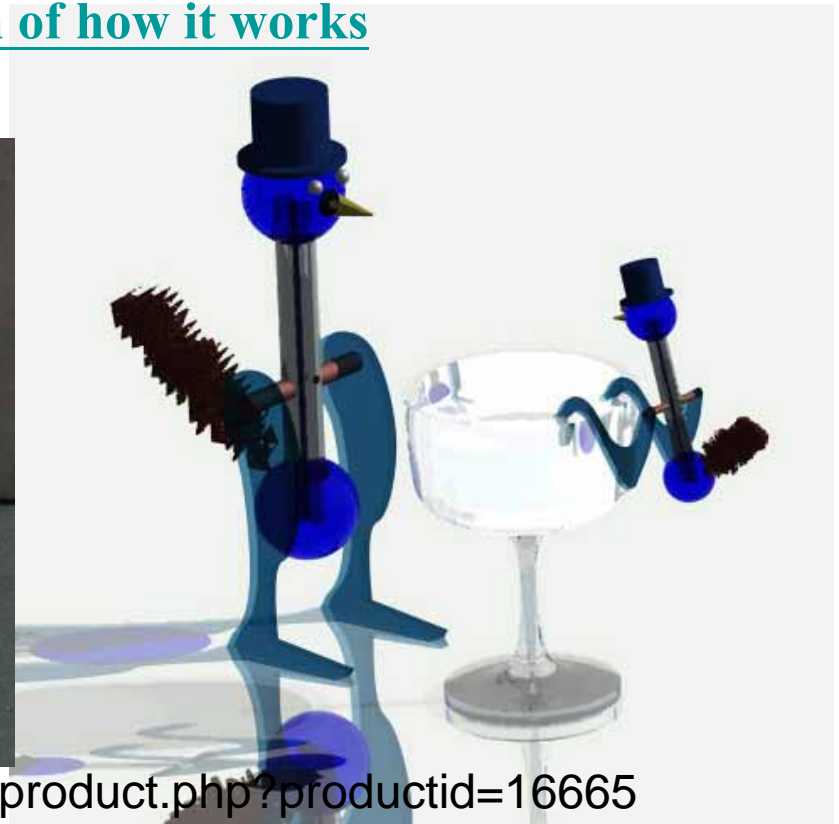
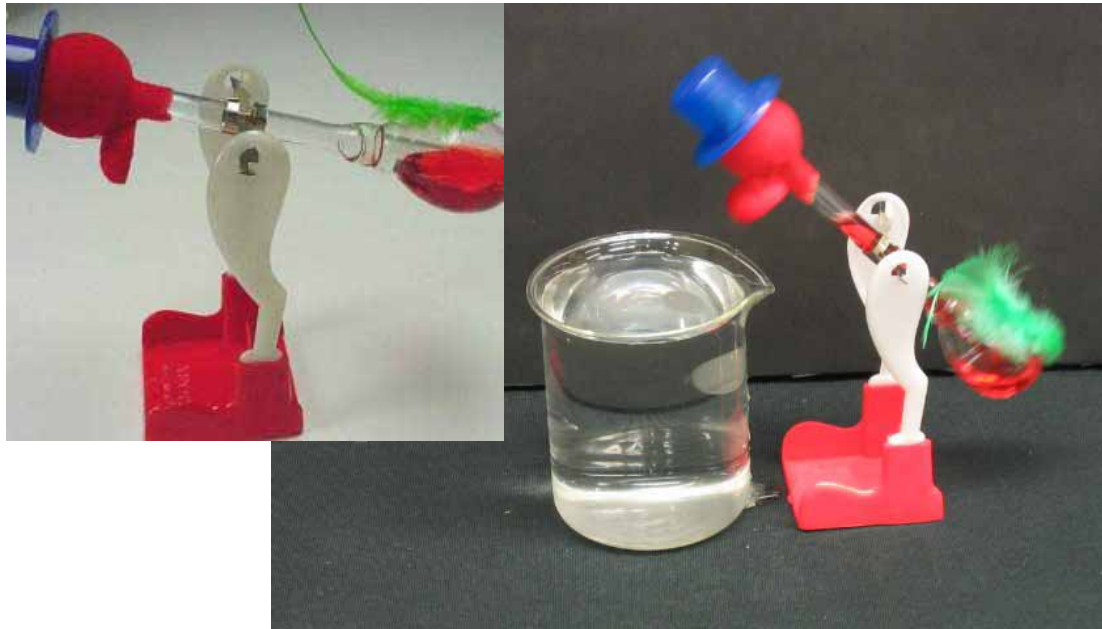

<http://noether.physics.ubc.ca/xcart/product.php?productid=16665>

Thermodynamic Boiler

-液氣相轉變示範實驗

- This thermodynamic hand boiler is made of hand-blown glass.
- The liquid inside these beautiful boilers shoots up the tubes and appears to boil when you hold it in your hand.
- 封閉的玻璃容器內，裝有酒精等易揮發的液體。
⇒ 在下端以手掌握住後，由於溫度升高，液體轉變成氣體。
⇒ 在固定容積內，溫度上升，氣壓增加，便將下部的液體推擠至上部的球中。
⇒ 手一拿開，溫度回降至室溫，氣壓隨之降低，上球的液體又流回下球中。
- 簡單有趣的小道具，可以清楚地解釋液氣相的變化、空氣壓力等物理現象。



<http://tw.9s2u.com/>



Hand Bubbler Boiler Pen

Demonstrates Energy Transfer

- Hold the bottom chamber between your fingers and watch as your body heat warms the liquid.
- As it starts to vaporize, it expands moving it's way through the tubes to the upper chamber. When all the liquid has reached the top, a bubbling effect is created!
- Let go and the liquids cool, and move back down to the lower chamber. Great for science class! Includes matching stand.
- **WARNING:** Not intended as a toy for children.
 1. **Contains Ethyl Alcohol.** Avoid contact with eyes. In case of eye contact, flush thoroughly with water. If irrigation persists, get medical attention.
 2. Do not use near heat or flames. Only warm using your hand. Liquid will stain if glass is broken.
 3. Keep out of reach of children.

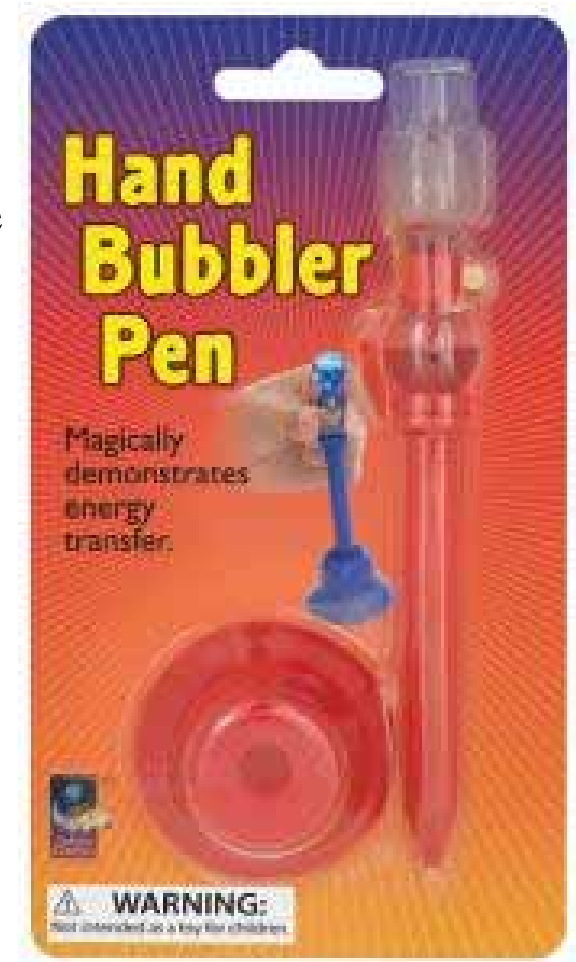

輻射計(Radiometer)

-光熱轉輪

現象：黑白葉片照光會轉，
是光壓作用？還是電磁作用？
能否反向轉？
可否以其他方式也使之旋轉？

目的：觀察黑白葉片旋轉的機制

實驗：

1. 封閉玻璃容器的中間支撐一可自由旋轉的轉輪，轉輪由四片葉片組成，葉片的兩面分別為黑色與白色。
2. 當使用光源(傳統檯燈，太陽光，手電筒皆可)照射到葉片上，便會逐漸開始轉動。移開光源，葉片即停止轉動。
3. 改以雷射筆或LED燈泡的手電筒照射葉片時，轉輪不會轉動。
4. 用手電筒照射葉片白色那面時，轉輪不會轉。但照到黑色那面時，轉輪就迅速轉動起來。
5. 分別(1)改用吹風機以加熱方式或(2)以熱乎乎的毛巾及(3)冰冷的毛巾包覆玻璃器的上端，再仔細觀察黑白葉片轉動的情形。



輻射計(Radiometer)深層思考

- 此裝置很容易由網路購得的科學小玩具，價錢僅約US \$ 10左右，台灣賣~NT\$650-800。提供給滿八歲以上的孩童於把玩過程，透過觀察有趣的物理現象，學習並探究其原理。但其中所蘊含的物理原理卻值得深思。
- **問題：為何葉片會旋轉？如何決定葉片旋轉的方向？**

如果是光壓？光子打到白色葉片時，動量變化應是打到黑色葉片的兩倍(想一想為什麼?)，所以不論照黑色面或白色面，轉輪應該都會轉，而且照白色那面時，應該轉動更快才是。可是這跟觀察三不符？

 1. 是電磁作用嗎？仔細觀察轉輪的結構，組成的都是元件都是絕緣體，如果是與電磁現象相關，會有產生電流或磁場等裝置，似乎沒有看到？
 2. 如果照光就會轉，那為什麼照射雷射光時，應該卻一點兒動靜也沒有？（觀察二）
 3. 難道是光電效應？那使用雷射或LED手電筒不是更好嗎？
 4. 照黑色與白色有差別？因為黑色容易吸熱，所以造成旋轉的機制與熱有關嗎？
 5. 為何以吹風機或冷熱毛巾的熱能也能啟動葉片的旋轉？

進一步更深度的探討

1. 玻璃容器內部是一大氣壓？還是真空？抑或是某特殊壓力？
2. 內部是否有氣體？有的話，是哪一種氣體？
3. 玻璃容器內部需要填充特別的氣體嗎？
4. 不小心打破玻璃容器後，直接照光於轉輪上還會有同樣的結果嗎？
5. 如果葉片不是一面黑一面白，若兩片全黑或全白，葉片照光還會旋轉嗎？
6. 若一黑一白的葉片改塗成其他不同的顏色，您認為現象會如何改變？
7. 可辦小型競賽，如比賽方式可比賽組裝使特林引擎的技巧，或利用光電閘紀錄飛輪轉動的圈數及總轉動時間，最多圈及時間最長者勝出。競賽可大幅提高學習者的實驗動機及趣味性。

咖啡杯上的史特林引擎 (Stirling engine)

透視引擎的視覺化運作！

目的：藉由透視史特林引擎的運作，瞭解抽象的熱力學循環過程。

實驗：組裝好的史特林引擎置於裝滿熱水的杯子上。熱水的熱能透過引擎氣室下方的金屬板傳導至氣室內金屬板和白色活塞之間的氣體。此時稍微撥動一下飛輪，引擎即開始轉動。當氣室上下兩金屬板的溫度差越大，飛輪則旋轉地越快。引擎就靠著熱水所提供的熱能量，持續轉動，直至水溫冷卻到接近室溫，引擎才逐漸停止旋轉。

工作機制：熱能 \Rightarrow 動能的能量轉換機制，即蒸汽引擎的工作原理

應用：(1) 早期推動蒸汽火車和蒸汽汽車前進的主要機制。

(2) 火力發電廠中帶動發電機高速旋轉發電的主要機制
發電廠中的能量轉換流程：化學能 \Rightarrow 熱能 \Rightarrow 動能 \Rightarrow 電動。



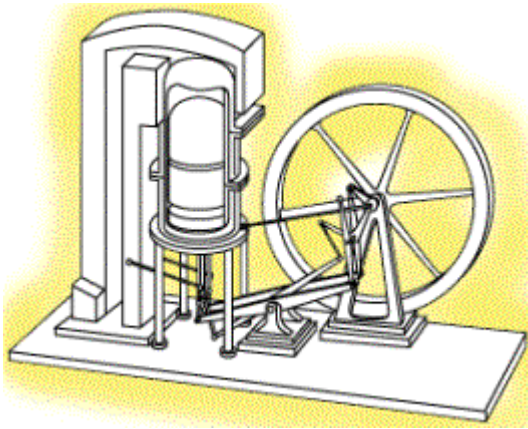

史特林引擎

-推動科技進步、改善人類生活品質
的關鍵性發明

史特林引擎，又稱發動機：是一種活塞式熱氣引擎

經由外部加熱裝有氫氣或氦氣氣體的密封氣室，使氣體受熱膨脹，進而推動活塞做功。

膨脹後的氣體在冷氣室冷卻，然後進入下一個流程。同樣只要有一定值的溫度差存在，都可以形成斯特林發動機，比如上面這個咖啡杯上的斯特林發動機，如果下面是冰塊，它也能轉起來，而且比裏面是熱咖啡（或熱水）還要持久，一個小時左右。斯特林發動機可以使用多種的燃料，各種可燃氣體估計是最佳材料，Dean Kamen還用牛糞來作過燃料。而且排氣潔淨，還有一個優勢相對於內燃機來說，因為沒有氣體爆炸，所以大大降低了噪音污染。



原理思考

史特林引擎中的熱力學循環過程

⇒ 「卡諾循環」 (Carnot-cycle engine)

左圖是引擎內工作氣體的工作圖 PV 相圖

- 縱軸是工作氣體的壓力
- 橫軸是工作氣體的體積
- γ 為工作氣體的體積壓縮比。

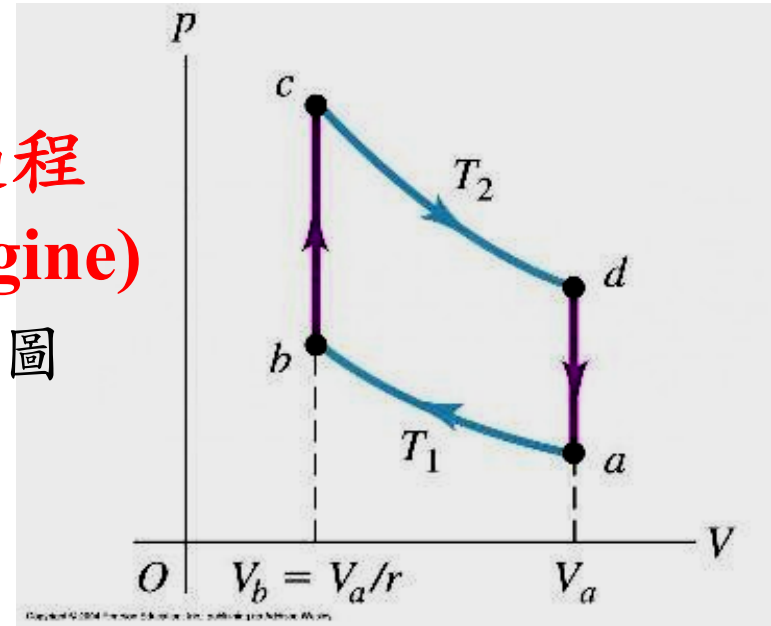

理想的史特林引擎是由兩個等溫過程及兩個等體積過程組成的熱力學循環。

- 等溫壓縮($a \Rightarrow b$)：工作氣體的溫度 T_1 不變，但壓力上升。
- 等體積加熱($b \Rightarrow c$)：從熱水的熱蒸汽中獲得熱能。
- 等溫膨脹($c \Rightarrow d$)：工作氣體的溫度不變 T_2 ，但壓力減小。
- 等體積冷卻($d \Rightarrow a$)：將熱能排至環境。

⇒ 理想狀況下，若 T_1 與 T_2 固定的情況下，史特林引擎的效率等於理想「卡諾循環」的熱機效率 $\epsilon_c = 1 - \frac{T_1}{T_2}$

深入探討

- 使特林引擎的循環對應的熱力學過程為何？
- 氣體在不同的階段和過程中，氣體的壓力、體積及溫度的關係為何？
- 飛輪的旋轉方向與引擎的機構設計有關嗎？還是由初始旋轉方向決定？
- 如果熱水的溫度增加，會影響什麼？
- 可用什麼方法讓引擎運轉的時間持續增加？

- 日常生活中充滿了使特林引擎運用的物品，您知道有哪些嗎？

問題：是熱縮冷脹嗎？

現象：通電，蝴蝶的翅膀會揮舞

老師的答案：這可不是熱漲冷縮哦！

目的：介紹反直覺的物理現象。

實驗：在一迴路中加入特殊金屬絲並通入電流，觀察通電前後特殊金屬絲的變化。

思考：一通電，物體就會被往上拉了？上頭是有裝馬達嗎？要不然怎麼一通電就往上拉。通電的目的是為了加熱該金屬絲，使其改變形狀，以達到此實驗所想表現的現象。

討論：請舉出非熱漲冷縮的例子。

備註：本實驗利用通電的方式加熱，取代用火所造成的不均勻加熱。

參考資料：[Wikipedia-Shape memory alloy](https://en.wikipedia.org/wiki/Shape_memory_alloy)

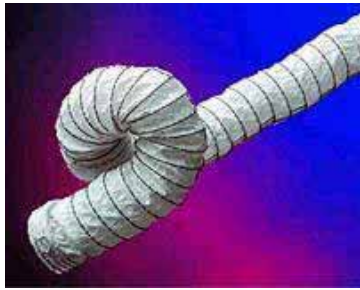

形狀記憶合金 (Shaped memory Alloy, SMA)



- 簡稱**記憶合金**，又稱**智慧型合金**。
- 是一種對**溫度特別敏感的特殊材料**，當環境溫度變化時，由於材料的內應力作用，使得材料發生變形，而當環境溫度恢復後，該材料也隨即恢復為原來的形狀，這就是所謂的**記憶合金**。
- 包括**鎳鈦合金**、**銅鋅合金**、**銅鋁鎳合金**以及**銅金鋅合金**等，現在也已有以**鐵合金**及**不銹鋼合金**製成的**記憶合金**材質。
- 除了**形狀記憶合金**之外，近些年來還出現了**形狀記憶塑膠**，某些**高分子聚合物**也具有**形狀記憶**的功能。例如，日本有一種**形狀記憶塑膠**，它是**苯乙烯**和**丁二烯**的**聚合物**，這種**聚合物**加熱至**60°C**時，**丁二烯**開始軟化，而**苯乙烯**仍然保持堅硬，如此就能展現其**形狀記憶**的性能。
- **形狀記憶合金**和**形狀記憶塑膠**的開發，對於**玩具業**的發展有很好的推動作用。應用十分廣泛，在日本利用**記憶合金**推出了不少**新穎別致**的商品，可用於**玩具**、**電子產品**等領域。

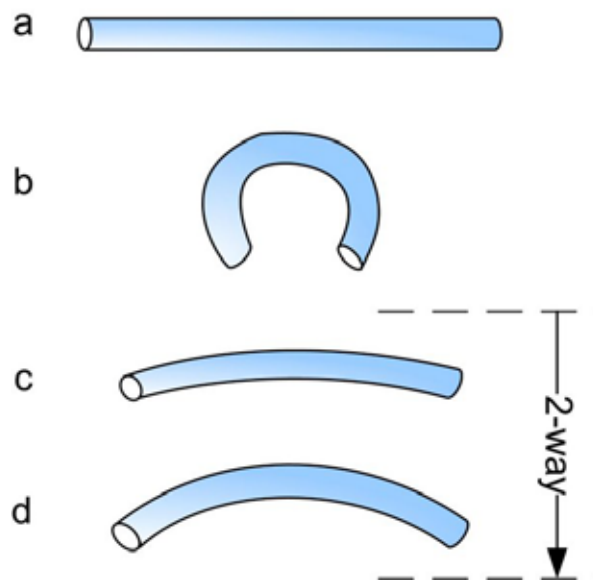
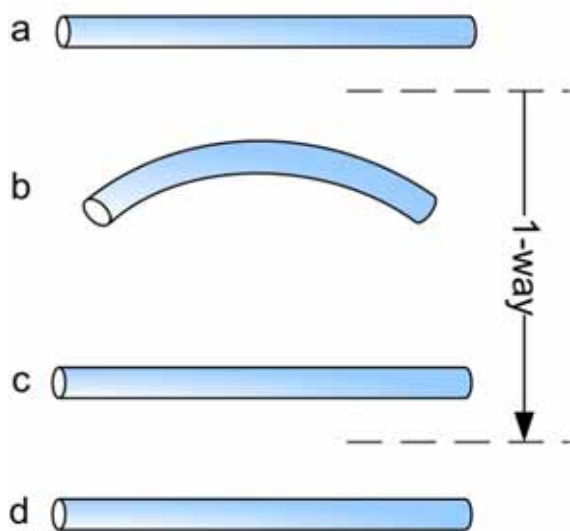
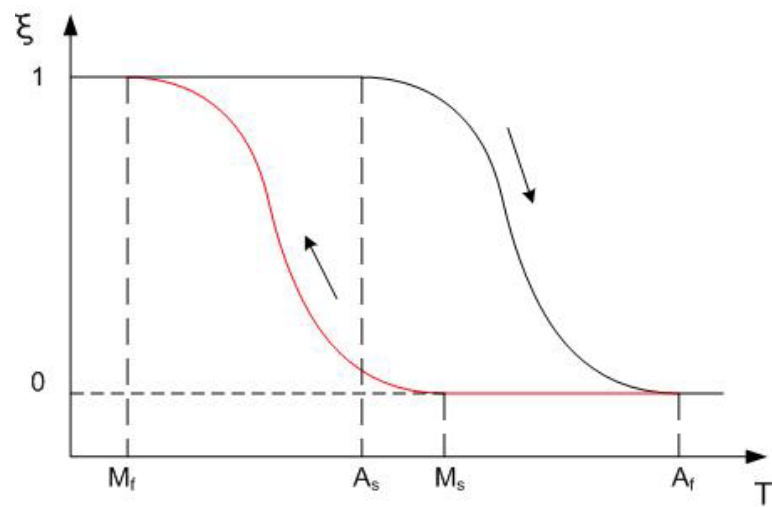

NIMS已開發出形狀記憶合金薄膜驅動器的簡易製造技術

-引自 2007/07/09【日經BP社報導】

- <http://big5.nikkeibp.co.jp/china/news/news/200707/mech200707090130.html> せ

記憶合金應用十分廣泛：

- 如機械上的固緊銷、管接頭，電子儀器設備上的火災報警器、插接件、積體電路的釐焊。
- 醫療上的人造心瓣膜、脊椎矯正棍、頭顱骨修補整形、口腔牙齒矯形和頷骨修補手術等。
- 在通訊衛星、彩色電視機、溫度控制器以及玩具等方面發揮神奇的效能，也將成為現代航海、航空、航太、交通運輸、輕紡等各條戰線上的新型材料。

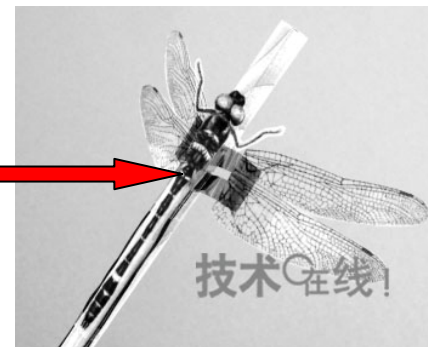
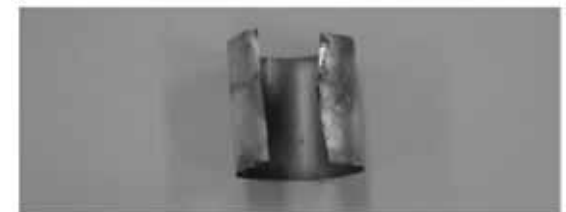

已上市的記憶合金產品

- 鈦鎳形狀記憶合金下尿路擴展支架
- 記憶合金食道支架
- 記憶合金作為防偽材料的應用
- 醫用高強度記憶合金矯形棒
- 一種記憶合金薄壁管內支架
- 網格狀記憶合金超彈性文胸托杯
- 記憶合金食道支架
- 記憶合金人體椎體
- 記憶合金防偽標誌
- 單側骨皮質記憶合金釘
- 一種記憶合金易拆卸環抱式加壓接骨器
- 記憶合金無聲脈動電機
- 記憶合金脊柱棒
- 形狀記憶合金溫控器
- 滅火器用記憶合金彈簧收縮式感溫驅動裝置

Ultraviolet Detecting Beads - UV Science and Fun

- These UV beads are an inexpensive fun way to make the invisible become visible.
- The solar pony beads are pale in visible light, such as indoors or if they are shielded by a UV screen such as automobile glass or sunglasses. The Ultra-violet sensitive beads contain a pigment which changes color when exposed to UV light from the Sun or other UV source.
- Many of today's space telescopes observe colors of light not in the visible spectrum such as infrared and ultraviolet.
- One can make a simple bracelet from a standard pipe cleaner or strip of rawhide which can function as a UV detector. Use your imagination to think of other things to use them for.
- Many other experiments are possible as well... [test sunglasses for the effectiveness of their UV protection](#), or even [suntan lotion](#).
- In five assorted colors, all beads are pale, off-white in the absence of UV light.
- The ultraviolet beads will cycle back and forth (to bright colors and back again) over 50,000 times!
- Become an ultraviolet detective with these amazing UV-sensitive beads! It's solar magic in action!
- Make bracelets, test the effectiveness of sunscreen, or experiment with color while you learn about the power of sunlight. Included is a science activity guide with lots of fun experiments with solar radiation and light.

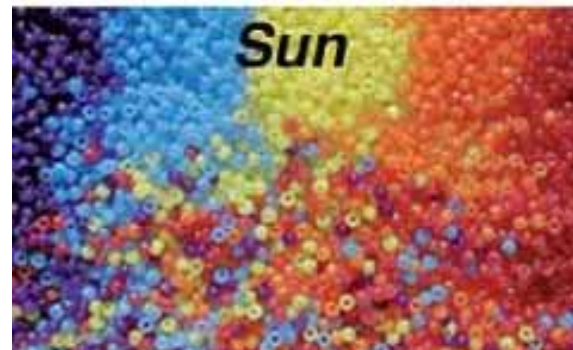

紫外光激發變色材料與防偽油墨

- 在太陽光下，能發出可見光(400~800nm)的材料和防偽印刷油墨。
- 這類材料和油墨從表面上看是由於太陽作用而變色，實質上也是受紫外線照射而變色的。
- 目前市場上已開發應用的此類材料在太陽光(也可在紫外光)下，即發生變色效果，可以從無色變紫、藍、黃等色，也可設計為從有色到無色變化。
- 是防偽材料中的新秀、奇葩。

Ultraviolet Detecting Beads - UV Science and Fun

- Become an ultraviolet detective with these amazing UV-sensitive beads! It's solar magic in action! Make bracelets, test the effectiveness of sunscreen, or experiment with color while you learn about the power of sunlight. Included is a science activity guide with lots of fun experiments with solar radiation and light.
- Ultraviolet Beads glow with bright colors when exposed to the sun or other UV light source, but remain off-white when indoors or not in the presence of UV.
- Students can use UV Beads to design and conduct experiments that test the effectiveness of UV protection: sunglasses, sun-block, and automobile glass for example.
- Combine science and art to create jewelry and other fun art projects using the beads. String the colorful little UV indicators together to create necklaces or bracelets that double as UV detectors. " "



World's Largest Solar Bag

- This amazing item demonstrate principles of density and buoyancy, as well as solar energy and laws of gases.
- The largest on the market today, this solar bag is 50 feet long and 3 feet in diameter and can be cut in half to make two bags the same size or two different sizes.
- The thin, black plastic bag holds over 350 cubic feet of air.

Experiments (實驗步驟) :

- Fill the bag by running, then tie up the ends and let the solar energy of the sun heat the air inside the bag.
- Tether the bag with string and watch it rise into the sky in only five minutes.



四、電學篇 + 五、磁學篇

- 韋氏起電機(Wimshurst's Electrostatic Generators)
- 范式(范德格拉夫)起電機(van de Graaf Generator)
- 靜電展示與應用
- 比比哪個磁力比較強？
- Spinning Magnet, Levitating Vortex 物體騰空懸浮歷久不墜
- Levitron-Floating Gyroscope

韋氏起電機

Wimshurst's Electrostatic Generators



構造：由一套安裝在基架上的透明塑膠盤(上有金屬片)和萊頓瓶(Leyden jarr就是電容器)組成

起電機的起電原理

利用感應起電，當兩個起電盤快速旋轉時，會使玻璃板的一半帶正電一半帶負電，間接使得裝有絕緣手柄的放電球頂部，分別聚集大量不同電性的電荷，不需接觸，即可大量放電。

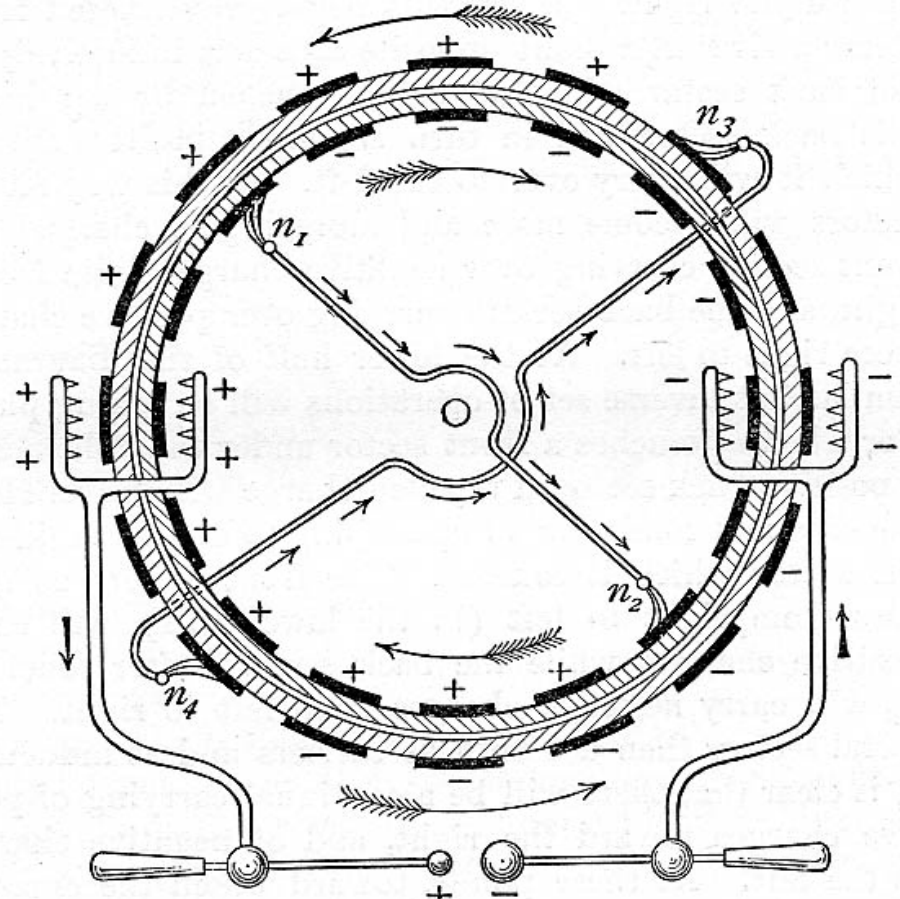
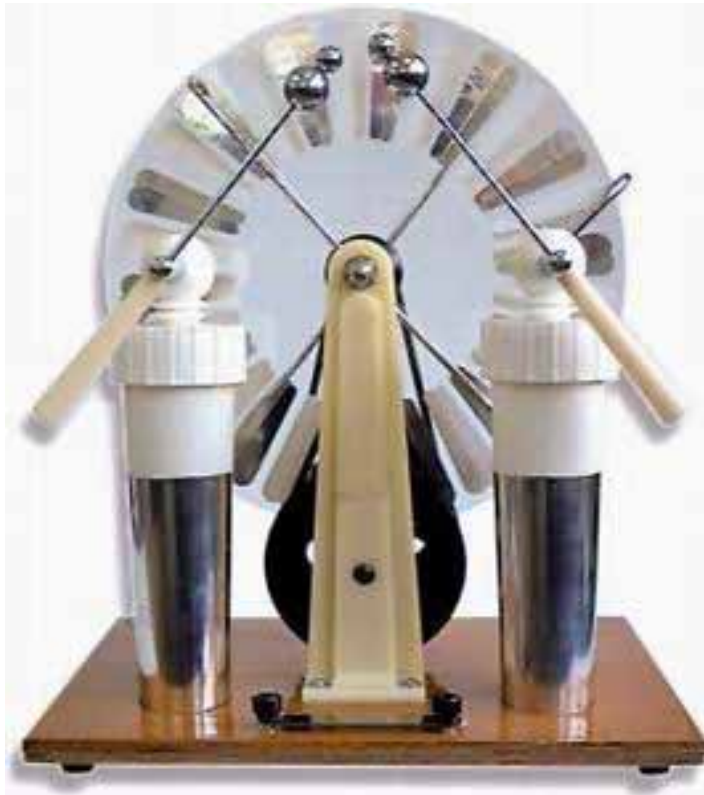

起電機使用的注意事項

1. 搖轉起電機時，必須順時針方向搖，如果逆轉將不能起電。
2. 搖轉起電機時，速度要由慢至快，轉速不可太高，否則會影響電刷和箔片的接觸，反而不能起電。
3. 轉動圓盤後，須注意放電球的極性，略微分開兩個放電球，慢慢轉動手柄，則帶負電的放電球上出現微弱的紫色光，帶正電的放電球上出現分叉的小火花。
4. 調節放電球的距離時，只能操作絕緣柄。如果停止起電實驗時，必須先將放電杆直接接觸，放電後才能觸摸各種部件。

感應起電機的性能指標

(1) 環境溫度 $5^{\circ}\text{C}\sim 30^{\circ}\text{C}$,

相對濕度 $< 80\%$

⇒ 火花放電距離 $\geq 30\text{mm}$

(2) 環境溫度 20°C ,

相對濕度 $< 65\%$

⇒ 火花放電距離 $\geq 55\text{mm}$



范式(范德格拉夫)起電機 van de Graaf Generator

范氏起電機是由美國科學家范德格拉夫(1901- 1967)於1931年發明的。起電機以摩擦生電的原理，不斷產生大量電荷。

右圖為學校普遍使用的起電機，內裡有一條橡皮帶，由膠輓帶動運轉。

可產生高達 $4 \times 10^5 \text{ V}$ 的電位



范式起電機原理

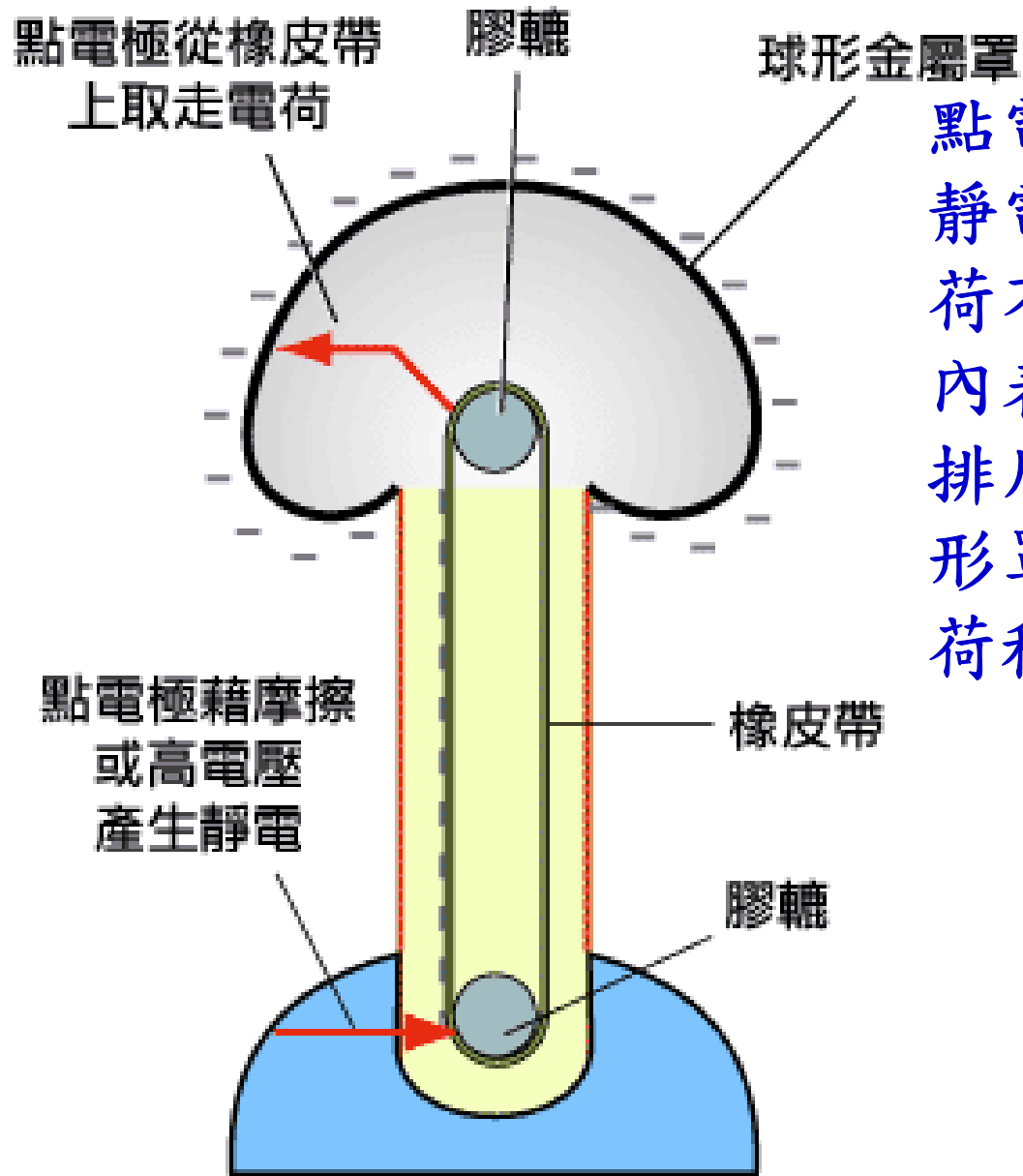

點電極藉摩擦或高電壓產生靜電，運轉的橡皮帶會將電荷不斷地傳到球形金屬罩的內表面。因為電荷之間互相排斥，所以電荷便移動到球形罩的外表面，形成大量電荷積聚在球形罩上。



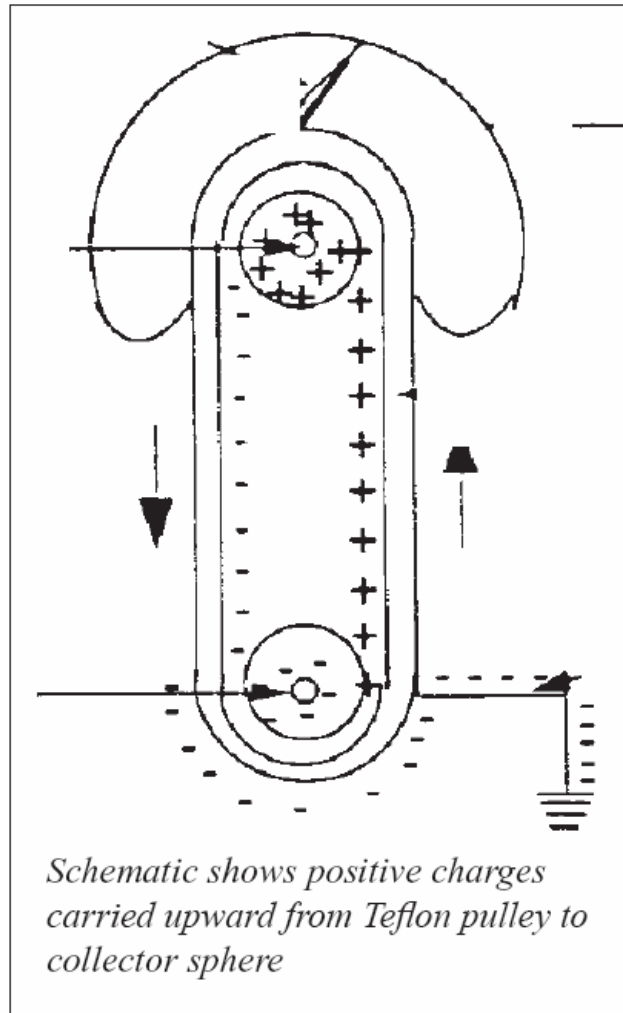

Demonstration:

- Hair Raising
- Electric Wind
- Lightning
- St. Elmo's Fire

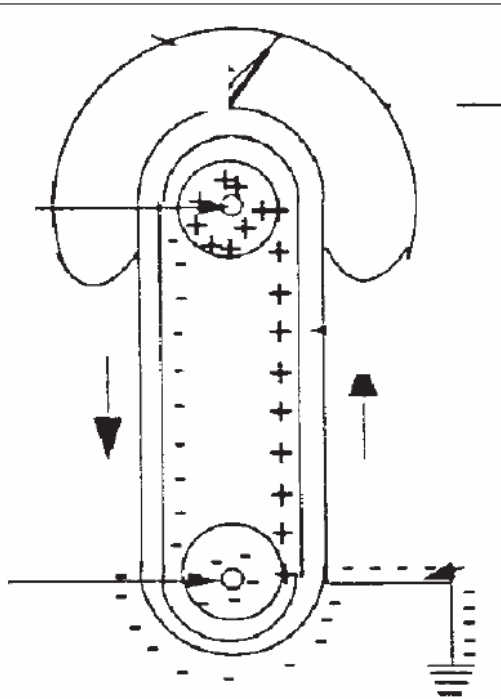

Schematic shows positive charges carried upward from Teflon pulley to collector sphere

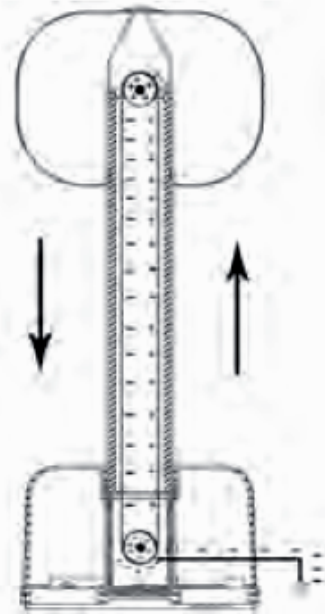

Start-Up

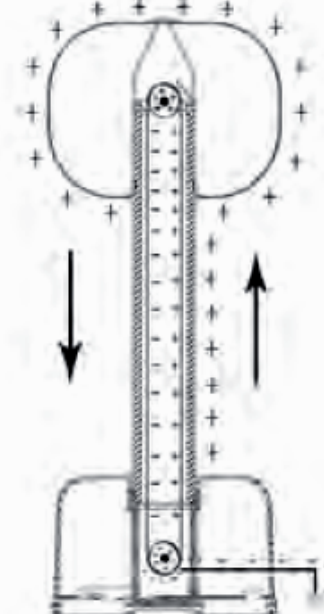

Combs reach ionization intensity

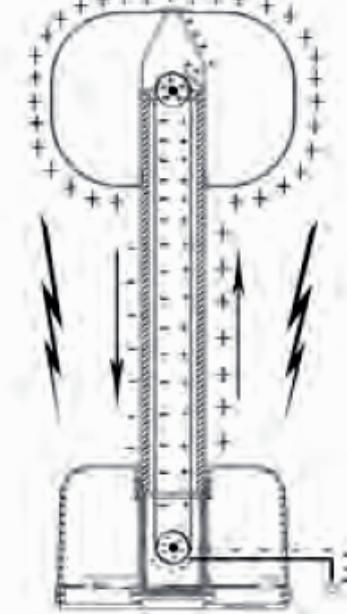

Dome reaches ionization intensity

Demonstrations: Hair Raising

<http://www.sciencefirst.com/>

Instructions file:

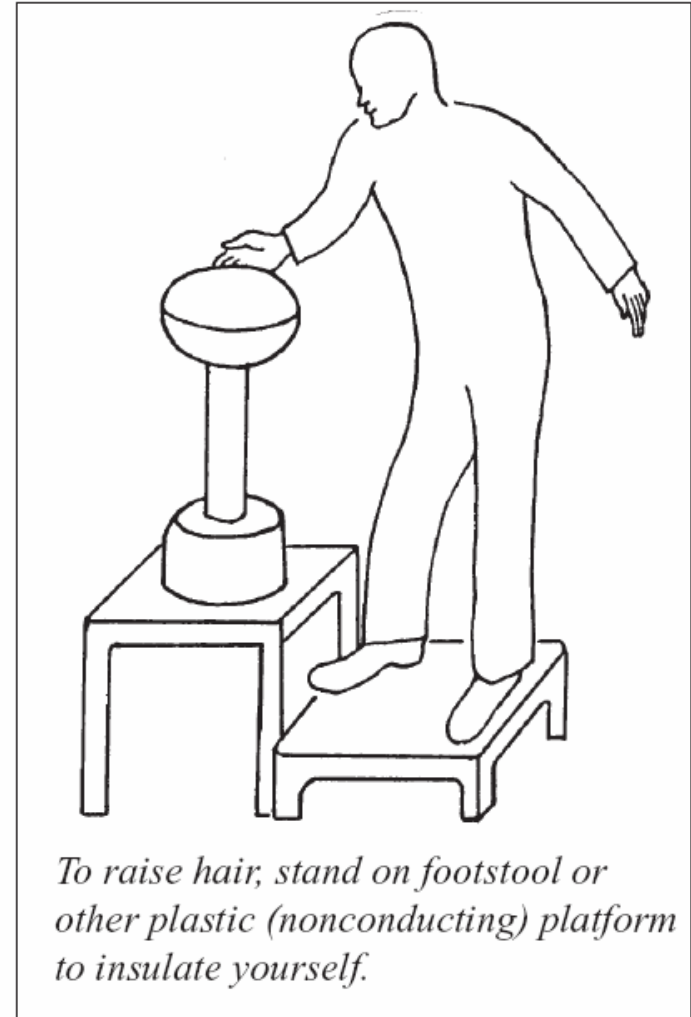

To raise hair, stand on footstool or other plastic (nonconducting) platform to insulate yourself.

Demonstration: Electric Wind

- **By attaching the conductor or needle, you have created an electric wind.** The conductor is in the form of a sturdy, light, thin metallic rod six to eight inches long (for instance, a darning needle) on the body of the collector dome, radially outwards. Use tape or clay to attach.
- The concentration of charges at the tip of the needle will be so intense that it will ionize air in its neighborhood. Negative ions will rush towards the collector dome and neutralize their charges. Positive ions, however, move away (due to electrostatic repulsion) from the generator and do not get neutralized.
- As the generator is continuously running, it keeps supplying more and more positive ions at a fast speed. The ions running away form a wind called “electric wind” which blows away (radially outward) from the generator.

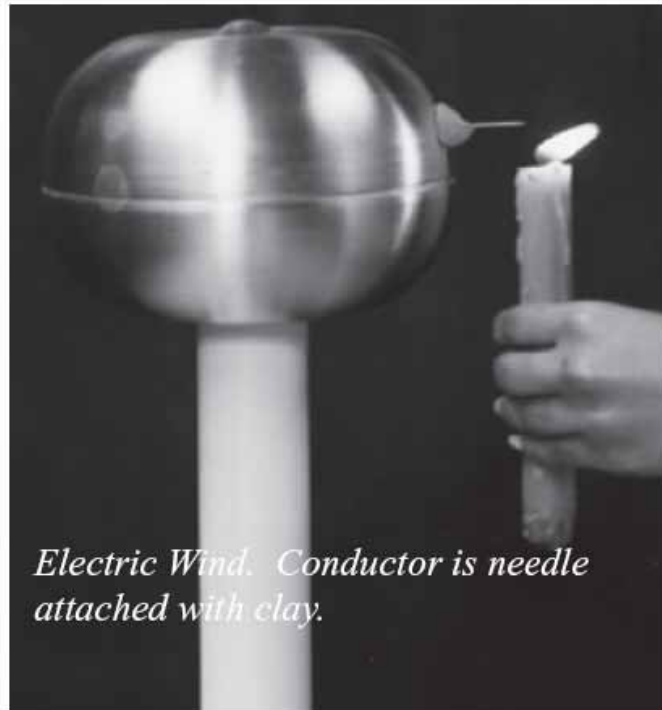

Using tape or clay to attach a conductor or needle :

- **Generate statics**
- **Turn a vane**
- **Spin a spinner**
- **Deflect a flame**
- **Rotate the collector dome**

Demonstration: Electric Wind

- **Generate Statics:** The wind is strong enough for its effects to be experienced as far away as 0 feet from the generator. It may not deflect a flame that far away but will certainly impart statics to your clothing which would cling to your body; or to a paper that would cling to your hand or to the wall.
- **Turn a vane:** Place a vane, such as a child's pinwheel, in front of the conductor.
- It will turn in the direction of the wind. See for yourself what the wind direction is and see if you can form some idea of how strong the wind is. Try a vane that is slightly stiff and requires a stronger wind to turn it.
- **Spin a spinner:** Make a small spinner using aluminum foil " across with 4 - 6 blades. Use a sharp pin to act as axis for spinner and mount the pin on a wooden or plastic stick. Try placing 2 beads on each side to localize the spinner. When brought near the conductor, the electric wind will spin it.
- **Deflect a flame:** Bring a lighted candle near the conductor. The flame is deflected away from the generator in the same manner as an air draft.

Demonstration: (2) Electric Wind

- **Rotate the collector dome:** Show how an actual (electric) wind can be created by ionized air molecules running away from the pointed conductor. The ionized molecules move away from the sharp or rounded end of the conductor in great numbers and at great speeds. This, according to **Bernoulli's Principle**, produces a low-pressure region in front of the tip of the conductor. The rear end of the conductor (attached to the dome) remains at normal pressure. This sets up a pressure difference near the conductor. By using it, you can rotate the dome.
- ✓ Attach two identical sharp or rounded conductors tangentially (not radially) to the collector dome at its equator (along the seam) on opposite sides and in opposite directions. Conductors can be attached with clay or tape. Observe how pressure differences in the vicinity of these conductors exert torques on the collector dome which begin to rotate slowly but steadily. The dome continues to rotate as long as the generator is running. The mass of the dome is in excess of 200 grams excluding masses of the conductors.
- ✓ The fact, therefore, that the dome will rotate solely due to the electric wind that is generated is a testimony to the strength of that electric wind.
- **Carry the Electric Wind:** In this experiment you bring the wind to the candle instead of bringing the candle to the generator to observe its effect on the flame. Prepare a large darning needle by securely attaching a well-insulated copper wire in the needle's eye. Attach the other end of the wire to the collector dome with transparent tape. Carry the needle as far as the wire will allow you to carry it. Place it near a candle and watch the electric wind (emanating from the needle's tip) deflect the flame or turn a vane or rotate a spinner.

Demonstration:(3) Lightning

- Lightning, an awesome natural phenomenon, is an electrical discharge between clouds and the ground.
- Create it in miniature with a Van de Graaff Generator due to the buildup of positive electrical charges on the dome.
- Bring a rounded object (metallic, for best results, such as a mixing bowl or juice can or **10-074 Discharge Wand**) near the dome.
- You may wish to wear a glove or use a dry towel to hold the objects as you approach the dome to minimize the likelihood of receiving a shock.
- The discharge that occurs between rounded object and collector dome is accompanied by a crackling sound and can be made brighter and more frequent by bringing the rounded object closer (from 2" to $\frac{1}{2}$ " away.)
- If you withdraw the rounded object, the discharges become feeble and less frequent and may be seen only in a darkened room.
- You should hear intermittent crackling sounds and see feeble sparks in darkness.

(4) St. Elmo's Fire:

Electrical discharges from clouds to the earth are of three different types.

- **Point Discharge:** There is no visible light or sound. Point discharges are responsible for the bulk of discharge between clouds and ground.
- **Corona Discharge:** It is accompanied by visible light but no audible sound. This is known as St. Elmo's Fire.
- **Lightning Discharge:** This is accompanied by blinding light and deafening sound.
- ✓ You can create St. Elmo's Fire in a dark room by installing a sewing needle perpendicular to the dome using a drinking straw or small plastic strip. Tape the needle to one end of the straw, hold the straw by the other end and press it lightly against the dome. (The object, of course, is not to obtain a shock as you approach the dome with your hand.)
- ✓ A small but significant glow or "fire" appears at the tip of the needle. St. Elmo's Fire can also be created by attaching a 3' long electrical wire (not solid, but stranded) to the eye of a sewing needle.
- ✓ As the strands are passed across the eye, fold and twist them with pliers to join the needle solidly to the wire's end. Connect the other end of this wire to the ground connector on the base of your Van de Graaff. (This procedure will not work if your receptacle has only two flat holes.)
- ✓ Now tie the needle perpendicularly to one end of a drinking straw using cord or tape. Hold the far end of the straw and bring the needle close to the dome to watch the "fire" glow. With this method, you can study the effect of distance on the glow. The glow will be stronger in the vicinity of the dome. As distance increases, the glow dims. Determine the "firing distance" - the distance over which the glow is visible.

(5) Lighting

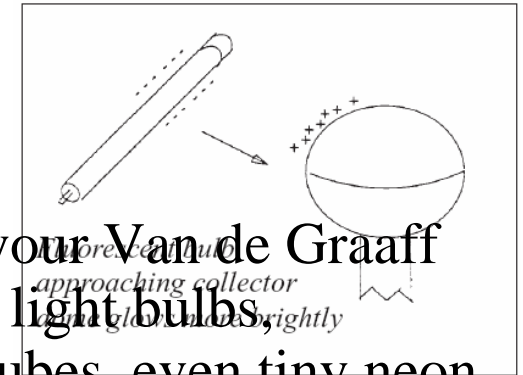

- You can light a variety of light emitting devices with your Van de Graaff Generator, for example – incandescent (filament type) light bulbs, fluorescent tubes or lamps, gas filled tubes, old radio tubes, even tiny neon tubes. For best results, do these experiments in a darkened room or at night.
- Bring your bulb toward the dome as the generator is operating. You may wish to make a nonconducting holder for the light bulb to avoid receiving a shock as you approach the dome. The outside glass surface nearest the dome acquires negative charge by induction. The charge builds up on the glass surface to discharge intensity. As discharge occurs, negative charges rush through the entire bulb, lighting it up for the duration of the discharge.
- Experiment with distances between bulb and dome. The bulb will light even when 2' away from the dome. Here, discharges will be stronger but the intervals between them will be longer. The light bulb will also glow more brightly. When you bring the bulb nearer, the discharges are more frequent but the light is dimmer. The bulb touches the dome, the light may be continuous (or flickering) but the intensity is low.
- Household (incandescent) bulbs will glow with purple light. Other gas-filled tubes will glow with the characteristic lights of the respective gases.

More Demonstrations

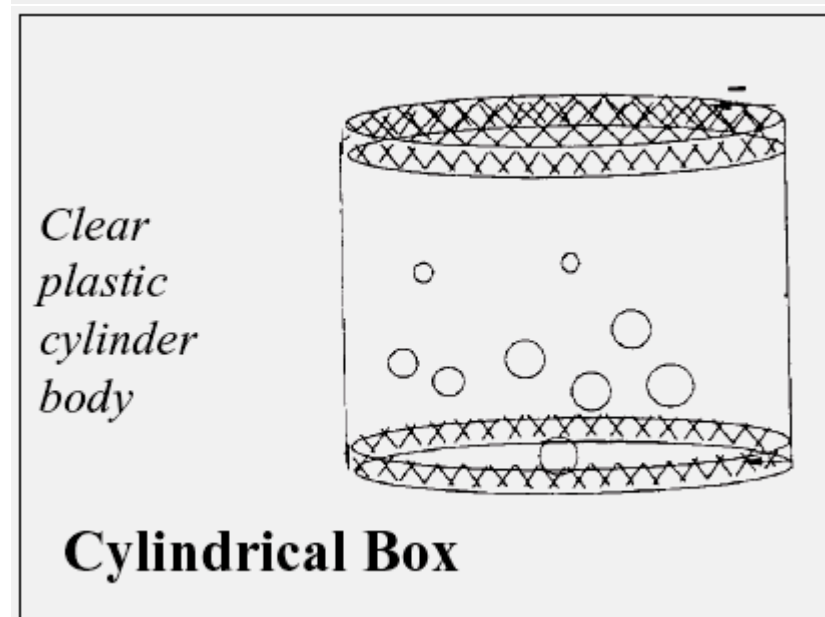
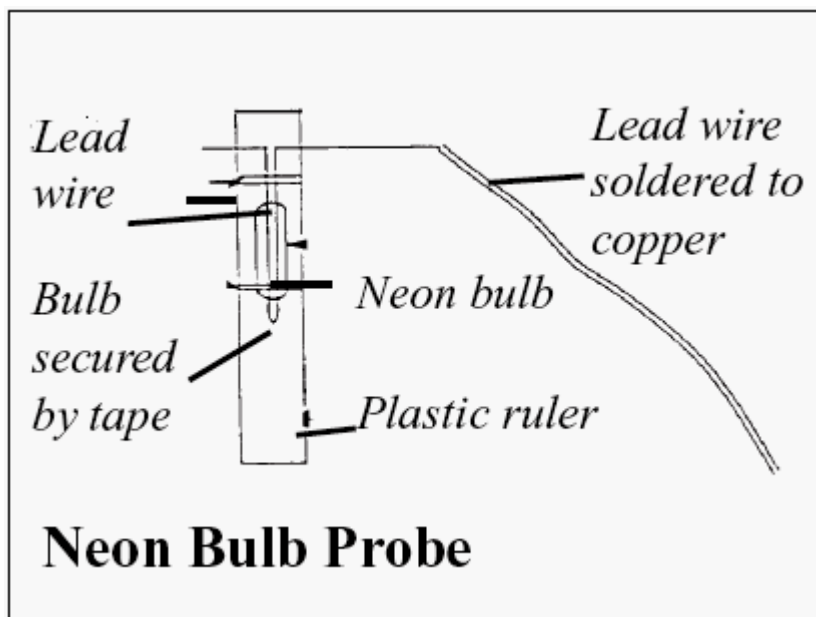
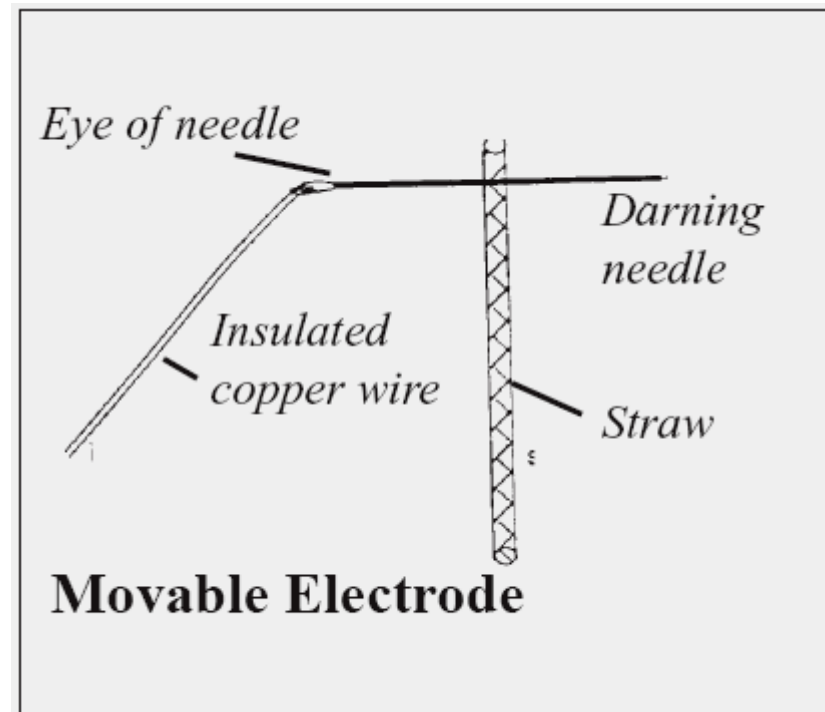
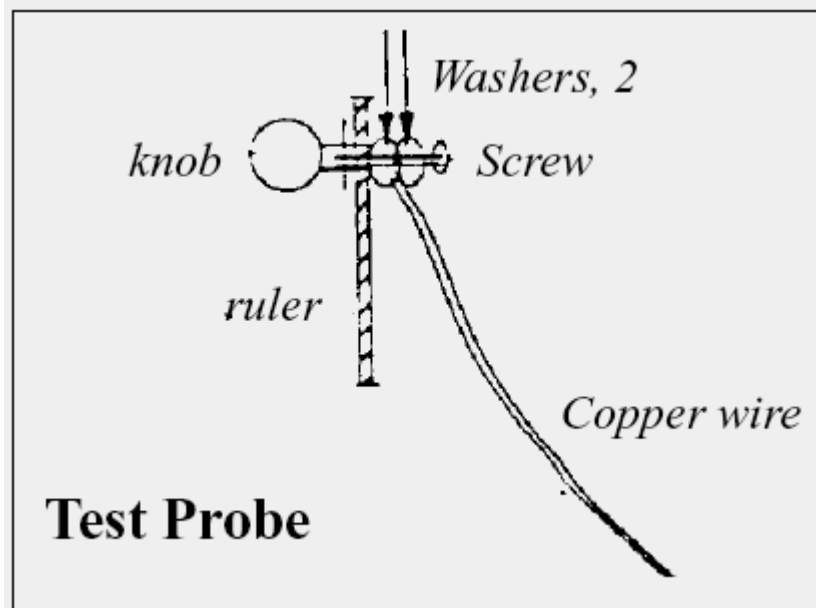

日常生活中的靜電

日常生活中有很多靜電的應用，如影印機、靜電除塵器、靜電噴漆。此外，認識靜電使我們避免它可帶來的危險，例如在運載易燃物品的車輛尾端繫上接地鐵鏈，把電荷傳到地面，以免電火花引致火災。同一道理，醫院的手術室裡，因為時常應用氧氣和易燃的麻醉藥物，所以地板通常是抗靜電的，而所有機器亦需接地，以免火花引發爆炸。

靜電感應起電器的運用

感應起電機在靜電學的實驗中是用來產生靜電高電壓，配合其他儀器進行關於導體表面的電荷分佈，靜電場的電力線，尖端放電和真空管(部分蓋斯勒管或克魯克斯管)的放電等實驗。也可以獨立進行靜電感應、火花放電、尖端放電和點容器(指起電機上的萊頓瓶)的電容量的變化等靜電實驗。

比比哪個磁力比較強？

兩組不同大小的磁鐵塊吸在一起時，比比看哪一組比較容易被拉開
A組兩塊體積較小的銀白色鈰鐵硼磁鐵(第三代磁鐵)，

B組則是體積大許多的兩塊氧化鐵磁體(一般常用的第一代磁體)。

第二組大體積的磁鐵塊可以很輕易地被分離；但體積小很多的第一組磁鐵塊，卻是用盡吃奶的力，仍不易撥得開。

強磁鐵使用時，請注意易夾傷手指，或掉落不易尋找，故請小心。



各種不同大小的鈰鐵
硼強力磁鐵

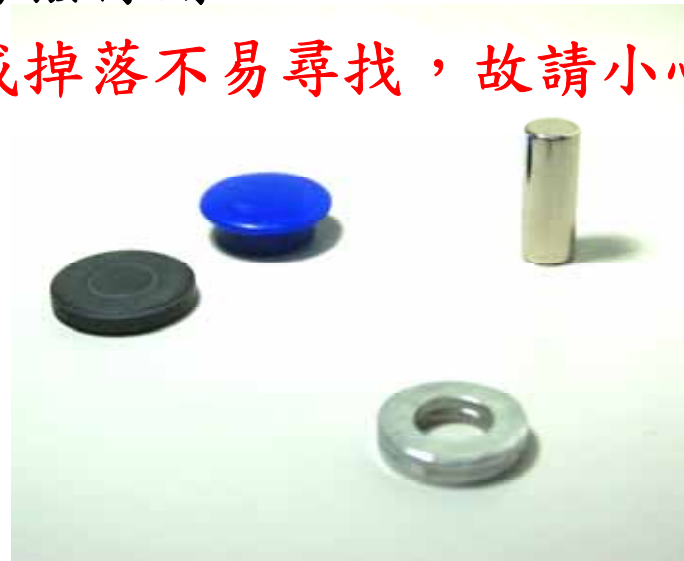

最左兩個圓片狀磁體為第一代氧化鐵
磁體，右邊長型圓體柱和中空環狀體
為第三代超強力鈰鐵硼磁鐵體)

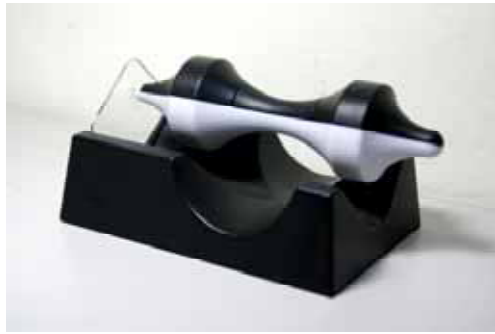

Spinning Magnet, Levitating Vortex

物體騰空懸浮歷久不墜

- Demonstrate magnet levitation and frictional force with our two-tone device. Black and white sections allow you to measure rotation speed with a stroboscope.
- 試試看您能否僅藉一個小小的側頂點支撐，讓一個物體如照片三所示，騰空靜止地懸浮於半空中。若果真使之懸浮於半空中的話，則除非有外力或地震擾動，否則可懸浮無限長時間歷久不墜喔！



可使筆頂懸於藍色環中的
創意造型筆座

應用於生醫領域的秘密武器

- 具定點導引功能的奈米磁流體
- 您知道嗎?! 讓我們將奈米科技與傳統磁性材料結合，可以大量生產奈米級磁性微粒，並可使之廣泛地應用於多種生物醫學檢測和醫藥治療的應用上。讓我們來觀賞磁力對奈米磁微粒和磁流體作用的有趣情形。

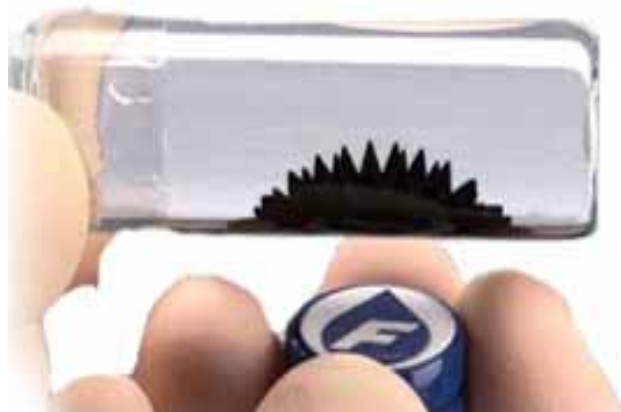

磁性奈米微粒受磁力作用的情形

無限寬廣的磁性應用

- 資訊記錄應用：奈米磁粒子大幅提升了磁記錄媒體的超高儲存容量，如磁碟、磁碟機、磁性記憶體、等等。
- 運輸應用：想像在未來的世界，超高速、無噪音、無磨擦(不接觸鐵軌)兼節能省電又環保效益的磁浮列車可成為人類理想的交通工具。
- 工業應用：磁懸浮式旋轉機制使旋轉軸承少了摩擦阻力的限制，所以可製造高速旋轉儀器，如高速分子渦輪幫浦、高速渦輪引擎、汽車引擎、等，超強磁鐵材料更使得發電機的發電效率大幅提昇。
- 生物醫學應用：特別觀賞磁力對奈米磁流體的導引效應，廣泛地應用於多種生物醫學檢測和醫藥治療的應用上，如定點標靶藥物傳輸、大幅提高基因治療的有效轉殖效率、改進醫學影像對比劑的效應與磁熱治療，以及快速有效地分離細胞、DNA和各種生物單元等等。
- 其他應用：您能否提出磁力和磁性材料還有什麼樣的應用？

Levitron-Floating Gyroscope

Demonstration film:

[Levitron-1](#)

[Levitron-2](#)



<http://www.levitron.com/physics.html#intro>

- [How does the LEVITRON work](#)
- [What holds the top up?](#)
- [Why does it need to spin?](#)
- [Why doesn't the top slip sideways?](#)
- [Why is the weight so critical?](#)
- [Why does the top eventually fall?](#)
- [Is the LEVITRON Principle used elsewhere?](#)

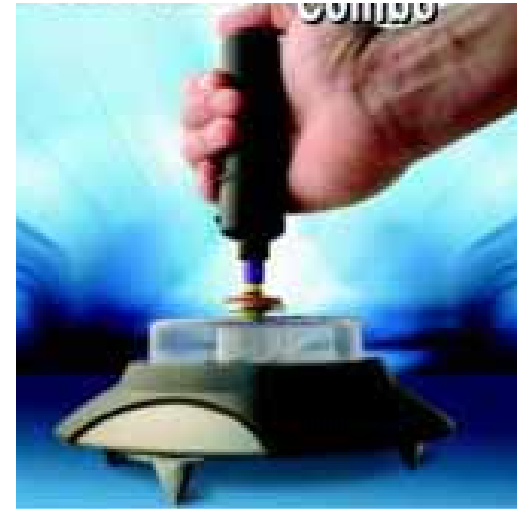

How does the Levitron work?

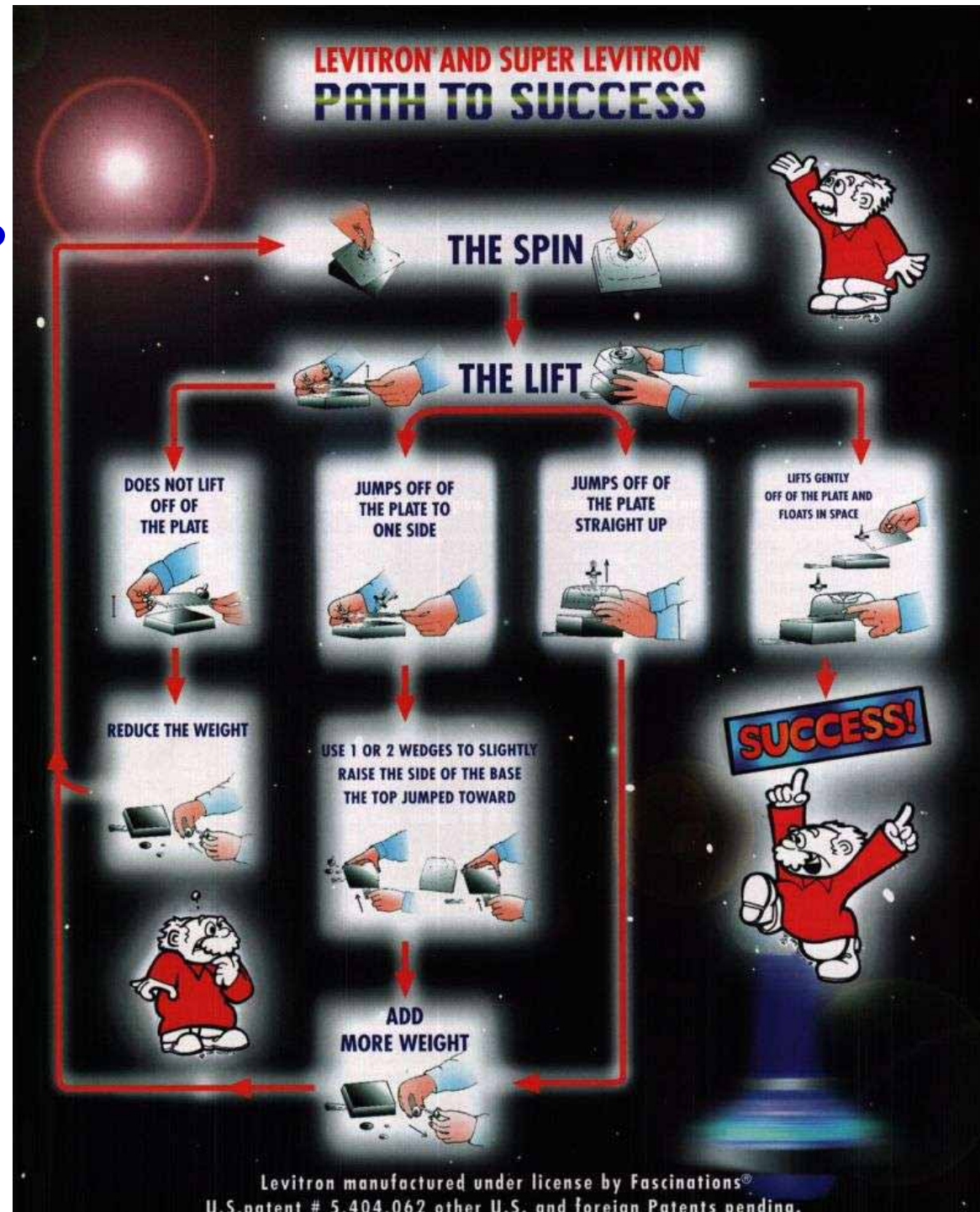

What hold the top up?

- The 'antigravity' force that repels the top from the base is magnetism.
 - Both the top and the heavy slab inside the base box are magnetized, but oppositely.
 - Think of the base magnet with its north pole pointing up, and the top as a magnet with its north pole pointing down (fig 1).
 - The principle is that two similar poles (e.g., two norths) repel and that two opposite poles attract, with forces that are stronger when the poles are closer.
 - There are four magnetic forces on the top: on its north pole, repulsion from the base's north and attraction from the base's south, and on its south pole, attraction from the base's north and repulsion from the base's south.
 - Because of the way the forces depend on distance, the north-north repulsion dominates, and the top is magnetically repelled.
 - It hangs where this upward repulsion balances the downward force of gravity, that is, at the point of equilibrium where the total force is zero.
- Dr. Michael V. Berry of the University of Bristol. Dr. Berry, inspired by this recognition, published a thorough exposition of the physics of the LEVITRON's operation.

The LEVITRON[®]

A Challenge To Master; A Miracle To Behold!

Read carefully and you too will find the PATH TO SUCCESS.

The key elements you need to master in order to successfully levitate the top are detailed in the following sections:

- Section I How to spin the magnetic top on the lifter plate over the center of the magnetic base.
- Section II How to determine the correct amount of weight that the top requires to float.
- Section III How to orient the magnetic field of the base magnet.

I. THE SPIN "First let's learn to spin the magnetic top over the center of the very strong base magnet."

Before trying to spin the top, take off all of the weights (washers) except for the large brass washer. Secure the washer to the spindle with one of the rubber grommets provided (black "O-Ring").

Next try to spin the top using a slight downward pressure on the lifter plate, keeping in mind that the top wants to flip over until its spinning at least 18 RPS (Revolutions Per Second). For this reason it is important that during the "spin-up" the spindle be grasped between the thumb & forefinger tightly (pinched) and as low as possible on the spindle. The tip of your fingers should actually be touching the brass washer and parallel to the shaft of the spindle. **NOTE!** Keep your elbow raised! By keeping your elbow raised, you will also find it much easier to keep the shaft of the spindle straight up and down during the spin.

Ideally you would like to have the top spin smoothly with the spindle perfectly upright but a spin in which the spindle wobbles can also be a successful spin! By raising the lifter plate about 1/4" immediately after the "spin-up" even a wobbly spin may straighten out and become a successful spin.

If, after reading these instructions you are still not able to master the spin, you can contact your dealer and ask about the Levitron Self Starter. This is a low cost battery operated device which when placed over the tip of the spindle can be used to "spin-up" the top.

II. THE WEIGHT "Now let's learn how to determine how much weight the top will require to levitate."

The top comes with the following assortment of weight-adjustment washers which are used to balance the downward gravitational force against the upward magnetic force:

2	Large Brass	3 grams each
3	Small Brass	1 gram each
2	Red Plastic	0.4 gram each
1	Green Plastic	0.2 gram each
2	Yellow Plastic	0.1 gram each
2	Black Rubber Grommets ("O-Rings")	used to secure the weights to the spindle

The top gains stability by adding weight. The goal is to make the top float as stable as possible. This is accomplished by adding as much weight as possible to the top and still have it levitate. Of course if too much weight is added, the top will not float.

The top gains stability by adding weight. The goal is to make the top float as stable as possible. This is accomplished by adding as much weight as possible to the top and still have it levitate. Of course if too much weight is added, the top will not float.

Now, let's try to float the top. **Start with one large brass washer (3 grams) secured on the spindle:**

Step 1. Spin the top on the lifter plate over the center of the base magnet. (Practiced in Section I.)

Step 2. Raise the lifter plate approximately 1" above the surface of the base magnet. At this point continue lifting but very slowly (appx. 1/4" per 5 second interval). One customer commented that this lifting process is similar to carefully letting a car's clutch out! If the top is correctly weighted and the base magnet is properly oriented (Section III), the top will gently lift itself off the lifter plate and float in space when the top is raised to approximately 1.25 inches above the surface of the base magnet (or appx. 2.5 inches for the Super Levitron). However, chances of getting the weight and orientation correct on the first try is rare.

Step 3. Learn how to interpret the results of your levitation attempt. First ask yourself, "was the top light enough to lift off the plate as the critical height was approached or did the top just slide off the side of the plate as I continued lifting?" If the top slid off the side of the plate, then remove some of the weight from the top (for example you might remove the 3 gram weight & replace it with 2-1 gram weights) and go back to step one. If the top "jumped upward" off the plate it is too light; add more weight & try again.

By using this trial & error method, eventually you will determine the correct weight within 0.1 gram, i.e. 1 small yellow washer. The top will float only if its weight lies within a very narrow (± 0.1 gram) range of a "correct weight". You will find this correct weight by successive trials as described above.

III. THE ORIENTATION OF THE BASE **"Finally! Let's orient the magnetic field lines of the base magnet!"**

The final step in successful levitation requires that the magnetic field produced by the base magnet be precisely vertical. To achieve this it is sometimes necessary to insert the shims provided under one or even two edges of the base. Because we cannot see these magnetic field lines we must determine any adjustments by observing how the top reacts to the base.

As you experiment trying to find the correct weight for the top, notice whether the top tends to fall repeatedly to the same side. For example, if each time the top jumps off the lifter plate, it falls toward you and to your right, then the front right sides of the base need to be slightly raised. Two wedges (shims) are provided for this purpose. Slide the wedge slightly under the base at the midway point of the side or sides being raised. Then spin the top and lift again. Each time the procedure is repeated you must watch the top closely as it leaves the lifter plate to help determine what further adjustments of the wedges are needed.

REMEMBER! No matter how well you orient the base magnet, the top will not float stable unless it is carrying the correct amount of weight. (Refer to Step II.) **SO!** It is important to have the top at or near the correct floating weight **FIRST** before attempting final adjustment of the base magnet using the wedges.

FINAL NOTE . . . Once the correct weight for stable levitation has been found, only minor adjustments to that weight will be required for levitation in the future. Most of the weight variations are the result of minor changes in the strength of the magnetic material due to temperature changes. (Magnets tend to lose strength as they heat up.)

MAY THE FORCE OF LEVITATION BE WITH YOU AS YOU ATTEMPT TO MASTER the LEVITRON! GOOD LUCK!

Why does it need to spin?

- To prevent the top from overturning.
- As well as providing a force on the top as a whole, the magnetic field of the base gives a torque tending to turn its axis of spin.
- If the top were not spinning, this magnetic torque would turn it over.
- Then its south pole would point down and the force from the base would be attractive - that is, in the same direction as gravity - and the top would fall.
- When the top is spinning, the torque acts gyroscopically and the axis does not overturn but rotates about the (nearly vertical) direction of the magnetic field.
- This rotation is called **precession** (fig 2).
- With the LEVITRON the axis is nearly vertical and the precession is visible as a shivering that gets more pronounced as the top slows down.
- The effectiveness of spin in stabilizing a magnetically supported top such as the LEVITRON was discovered by Roy M. Harrigan (4).

Why doesn't the top slip sideways?

- For the top to remain suspended, equilibrium alone is not enough.
 - ⇒ The equilibrium must also be stable, so that a slight horizontal or vertical displacement produces a force pushing the top back toward the equilibrium point.
 - ⇒ For the LEVITRON stability is difficult to achieve.
- It depends on the fact that as the top moves sideways, away from the axis of the base magnet, the magnetic field of the base, about which the top's axis precesses, deviates slightly from the vertical (fig. 2). If the top precessed about the exact vertical, the physics of magnetic fields would make the equilibrium unstable.
- Because the field is so close to vertical, the equilibrium is stable only in a small range of heights - between about 1.25 inches and 1.75 inches above the center of the base. (between 2.5 and 3.0 inches for Fascinations' new Super LEVITRON).
- The Earnshaw theorem is not violated by the behavior of the LEVITRON. That theorem states that no static arrangements of magnetic (or electric) charges can be stable, alone or under gravity. It does not apply to the LEVITRON because the magnet (in the top) is spinning and so responds dynamically to the field from the base.

Why is the weight critical (and why must it be adjusted so often)?

- The weight of the top and the strength of magnetization of the base and the top determine the equilibrium height where magnetism balances gravity.
- This height must lie in the stable range. Slight changes of temperature alter the magnetization of the base and the top. (as the temperature increases, the directions of the atomic magnets randomize and the field weakens).
- Unless the weight is adjusted to compensate, the equilibrium will move outside the stable range and the top will fall. Because the stable range is so small, this adjustment is delicate - the lightest washer is only about 0.3% of the weight of the top.

Why does the top eventually fall?

- The top spins stable in the range from about 20 to 35 revolutions per second (rps). It is completely unstable above 35-40 rps and below 18 rps.
- After the top is spun and levitated, it slows down because of air resistance. After a few minutes it reaches the lower stability limit (18 rps) and falls.
- The spin lifetime of the LEVITRON can be extended by placing it in a vacuum. In a few vacuum experiments that have been done the top fell after about 30 minutes.
- Why it does so is not clear; perhaps the temperature changes, pushing the equilibrium out of the stable range; perhaps there is some tiny residual long-term instability because the top is not spinning fast enough; or perhaps vibrations of the vacuum equipment jog the field and gradually drive the precession axis away from the field direction.
- Levitation can be greatly prolonged by blowing air against an appropriately serrated air collar placed around the top's periphery so as to maintain the spin frequency in the stable range.
- Recently a LEVITRON top was kept rotating for several days in this way. But the most successful means to prolong the top's levitation is with Fascinations' new PERPETUATOR ? an electro-magnetic pulsed device which can keep the top levitating for many days or even weeks.

Is the LEVITRON Principle used elsewhere?

- In recent decades, microscopic particles have been studied by trapping them with magnetic and/or electric fields. There are several sorts of traps.
- For example, neutrons can be held in a magnetic field generated by a system of coils. Neutrons are spinning magnetic particles, so the analogy of such a neutron trap with the LEVITRON is close.

陀螺儀(Gyroscope)



- 一種根據角動量不減理論所設計用來感測與維持物體旋轉方向的裝置。
- 主要是由一個位於軸心可以旋轉的輪子構成，陀螺儀一旦開始旋轉，由於輪子的角動量，陀螺儀有抗拒方向改變的趨向。
- 多用於導航、定位等系統。

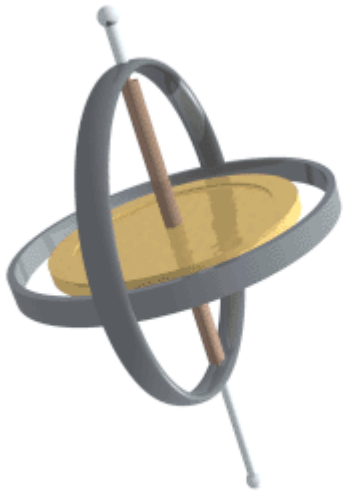

陀螺儀的歷史

- 1850年法國的物理學家福柯(J. Foucault)為了研究地球自轉，首先發現高速轉動中的轉子(rotor)，由於慣性作用它的旋轉軸永遠指向一固定方向，他用希臘字 gyro (旋轉)和skopein (看)兩字合為gyro-scopei 一字來命名這種儀錶。

六、光學篇

- **Ghostly Optical Illusion**-看得到卻捉不著的影像光學
反射鏡組
- 偏振(極)片(Polarizing Sheets)--光消失了，影像也就
看不見了!
- 掌上簡易光譜儀-使用光柵片製作簡易的光譜儀
- 物理學防偽技術
- 旋轉紙陀螺--將黑白變七彩!
- 折光潛影-偽鈔辨識、雙影像、動畫、、應用
- 具放大鏡功能之輕便可撓的塑膠放大片
- Morie Patterns
- Euler's disk

看得到卻捉不著的影像光學反射器

- 利用鏡面的多重反射，將底部的物體影像，聚焦在上蓋之上。
- 神奇的模擬出沙漠中海市蜃樓的幻景。讓大家看得到，卻摸不到它。
- 利用它，表演一手科學魔術，讓每個人臉上布滿驚奇之相後，再為大家解釋光反射的原理吧。

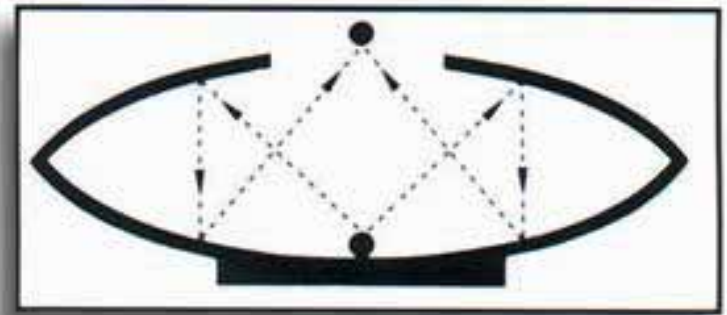

Ghostly Optical Illusion

- Light to Create a 3D Optical Illusion.
- You will be dazzled and amazed when your hand passes right through the floating object hovering above the Magic Mirage - Optical Illusion Generator.
- Any object placed inside the Mirage is reproduced in strikingly precise detail and floats in 3D space right before your eyes.
- This phantom reality is produced by **two precision-polished parabolic mirrors with improved Microglass Mirror Protection**.
- Comes complete and ready to use with instructions and scientific explanation.
- A great source of fun and mystery.



This phantom reality is produced by two precision-polished parabolic mirrors with improved Microglass Mirror Protection. Comes complete and ready to use with instructions and scientific explanation.

A great source of fun and mystery.

Features:

- Acrylic 9" in diameter
- No Electricity
- Amazingly simple design yet ahh-inspiring!
- Optic Mirage

親愛的！我把字變不見了！

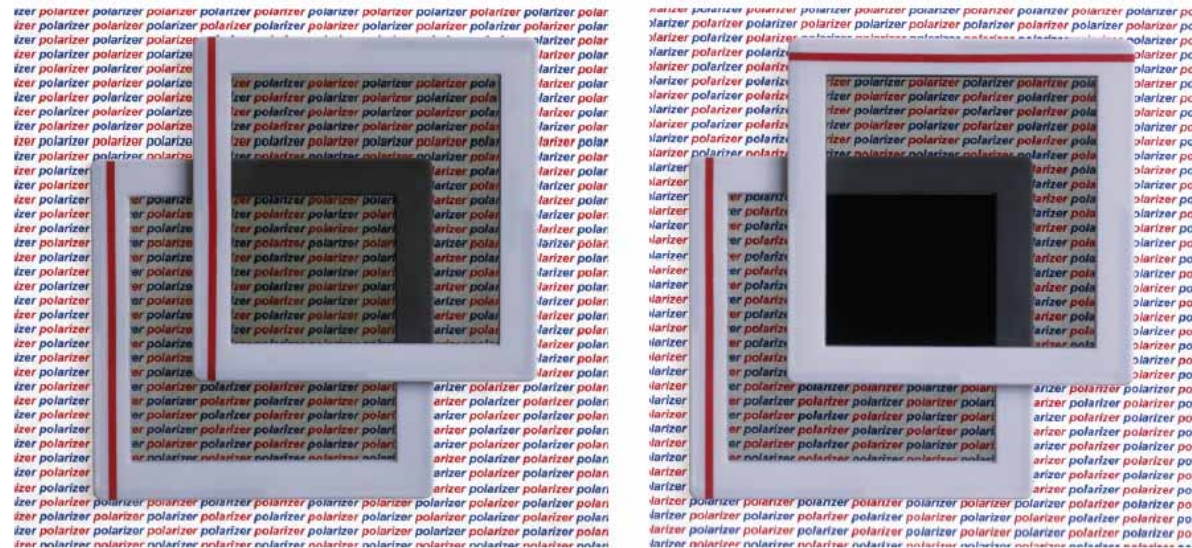

偏振(極)片
(Polarizing Sheets)
--光消失了，
影像也就看不
見了！

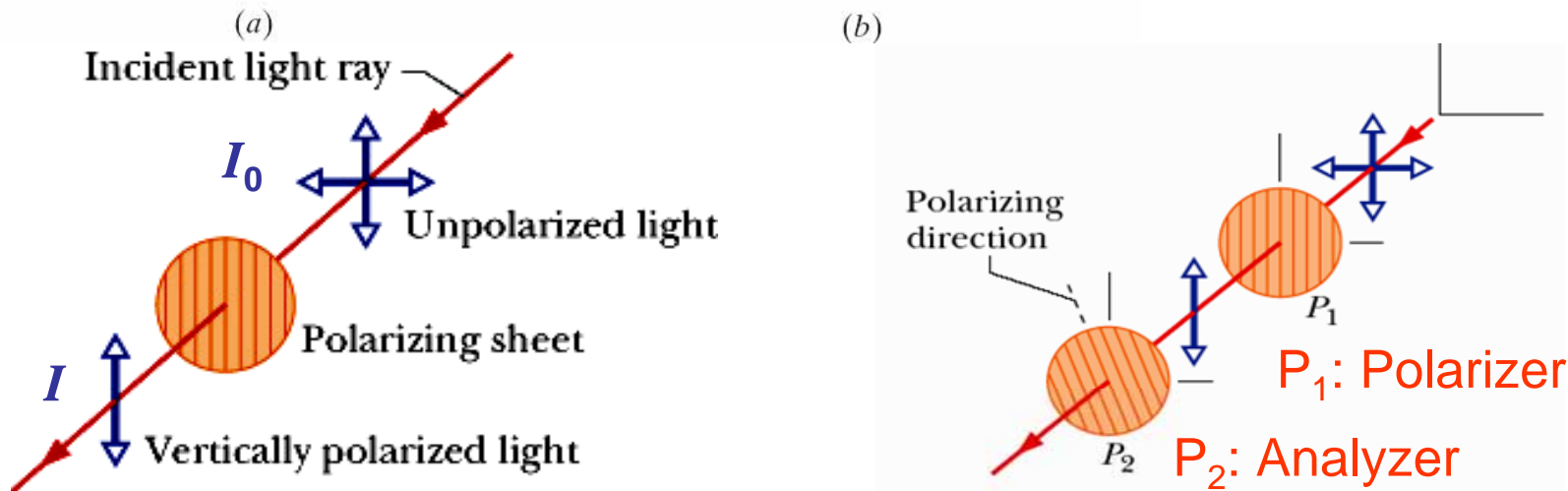

Only electric field component along polarizing direction of polarizing sheet is passed (transmitted), the perpendicular component is blocked (absorbed).

Polarized Light

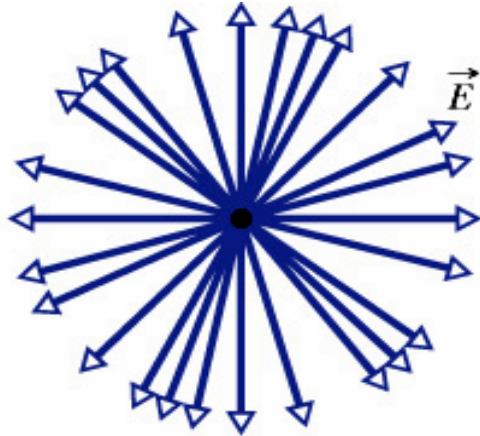

(a)

Unpolarized or randomly polarized light has its instantaneous polarization direction vary randomly with time.

One can produce unpolarized light by the addition (superposition) of two perpendicularly polarized waves with randomly varying amplitudes.

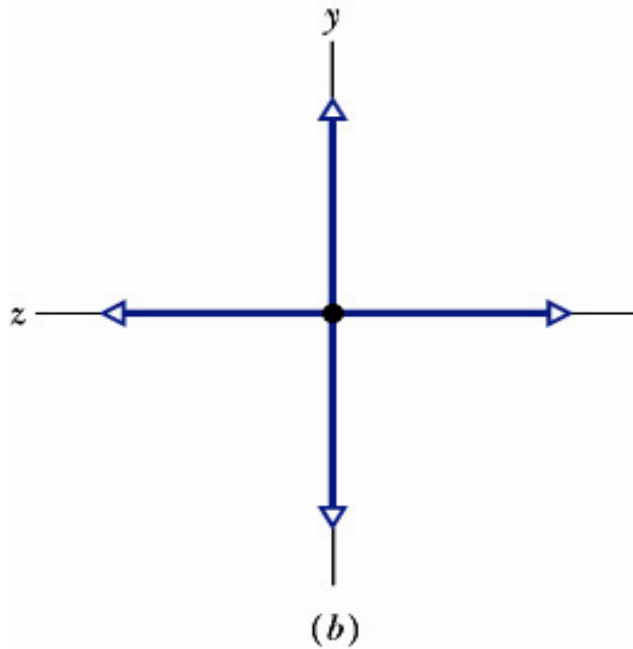

(b)

If the two perpendicularly polarized waves have fixed amplitudes and phases, one can produce different polarizations such as circularly or elliptically polarized light.

Intensity of Transmitted Polarized Light

One-half Rule

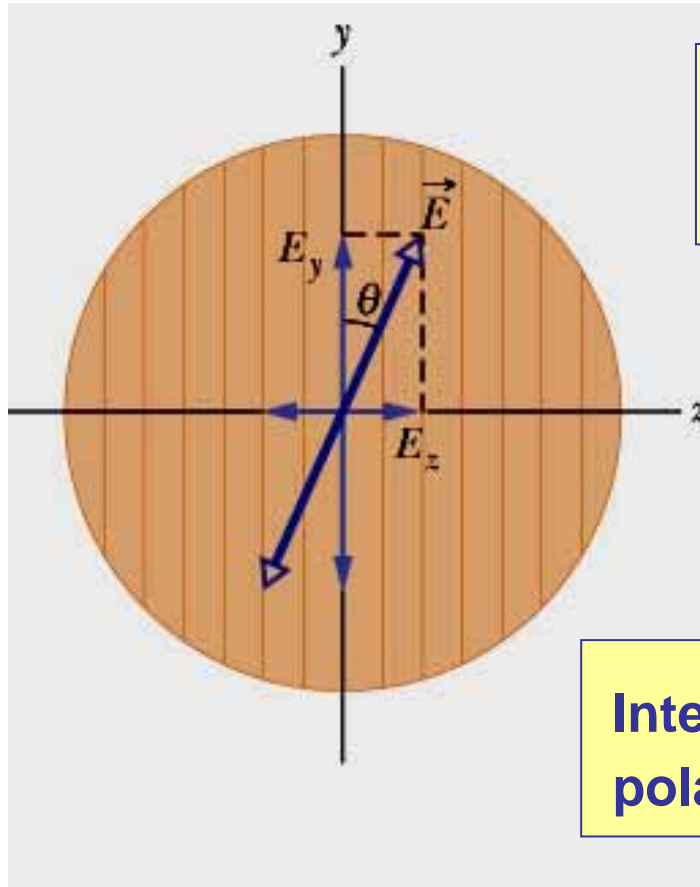

Intensity of transmitted light, unpolarized incident light: $I = \frac{1}{2} I_0$

Since only the component of the incident electric field E parallel to the polarizing axis is transmitted

$$E_{\text{transmitted}} = E_y = E \cos \theta$$

Intensity of transmitted light, polarized incident light: $I = I_0 \cos^2 \theta$

Cosine-sqaure rule: For unpolarized light, θ varies randomly in time

$$I = \left(I_0 \cos^2 \theta \right)_{\text{avg}} = I_0 \left(\cos^2 \theta \right)_{\text{avg}} = I_0 \frac{1}{2}$$



掌上簡易光譜儀

-使用光柵片製作簡易的光譜儀

目的：簡易的光譜(spectrum)分析

實驗：將掌中光譜儀的開口處對準光源，觀察光源所形成的光譜。

(1) 以日光燈為光源的光譜

(2) 以白熾燈為光源的光譜

(3) 以雷射光為光源的光譜



討論：若將此光柵置換成其它條數不同的光柵，對此實驗有何影響？

Maxwell's Rainbow

The full EM spectrum

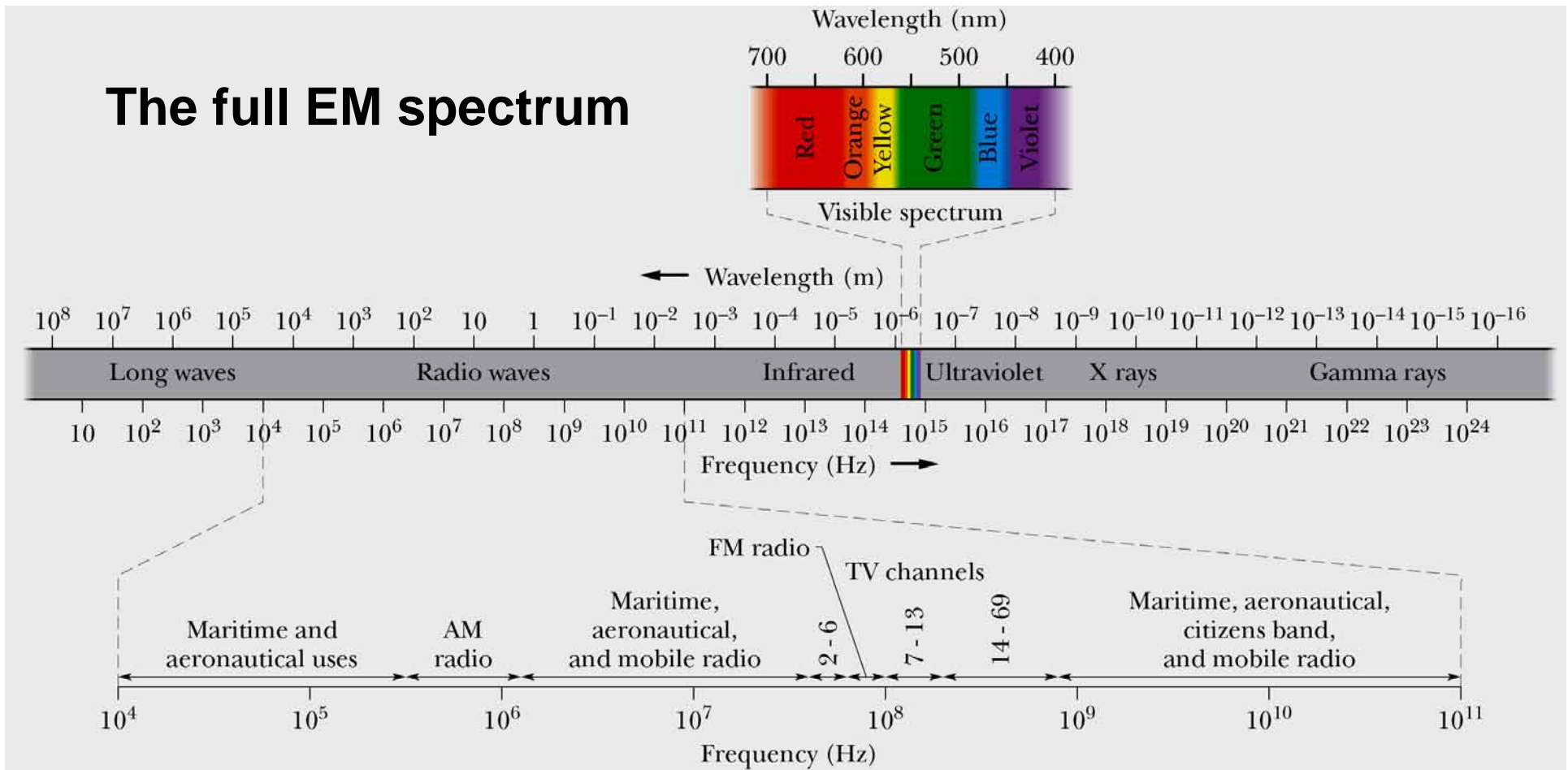

The wavelength/frequency **range** in which **EM waves** (light) are visible is only a tiny fraction of the entire electromagnetic **spectrum**

簡易光柵光譜儀的原理探討

- 平行光垂直入射光柵，狹縫與狹縫之間的距離為 $d = w/N$ (w ：光柵片寬度、 N ：狹縫數)，光通過在屏幕上任意之觀察點 P 產生干涉 (interference)。
- 光柵為一狹縫數 N 極大的多狹縫，當狹縫的數目極多時，狹縫之間的距離很小，每個縫所形成的繞射條紋會重疊而互相干涉，主要的干涉亮紋會變得非常狹窄而明亮，其它的干涉亮紋會相對較暗而看不見，因此，出現寬度極窄的干涉亮紋。
- 若要在 P 點形成一亮點，必需在該點形成建設性干涉，從相鄰兩狹縫出發光源的光程差是波長的整數倍

$$d \sin \theta = m\lambda, \quad m = 1, 2, 3, \dots$$

- 當方程式成立時，可得主要亮紋的位置。
- 因各色色光的波長不同
⇒ 故在相同 m 的下，
⇒ θ 值會不同
⇒ 故能看出各色光。

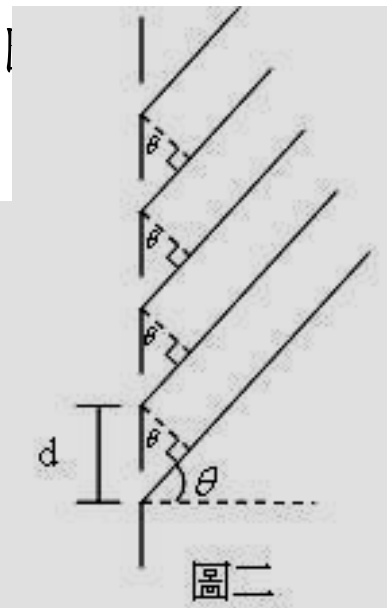
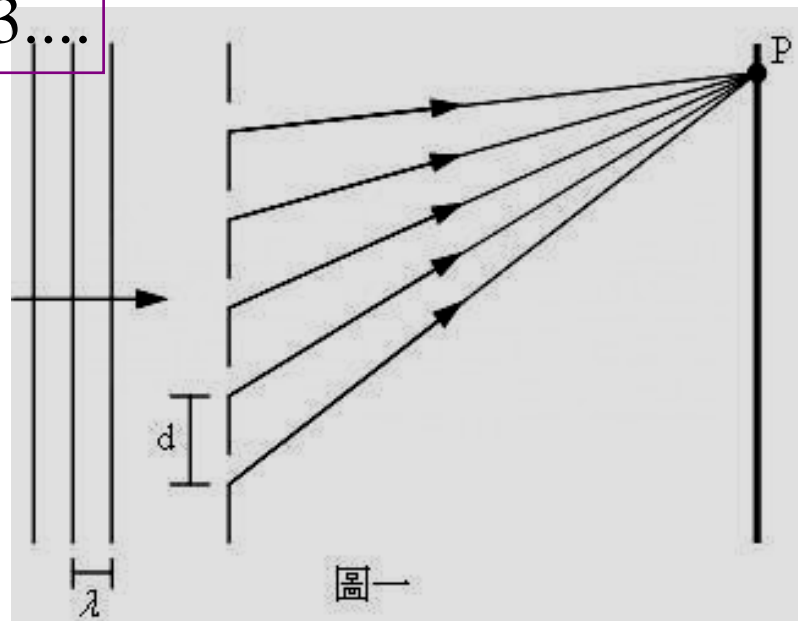

物理學防偽技術

1. 鐳射全息(雷射全相術)
2. 光聚合物全息圖防偽標識
3. 光學可變色薄膜
4. 超微棱衍射圖案
5. 熱色液晶
6. 超能防偽技術
7. 核徑偽雙卡防偽技術
8. 電碼電話防偽
9. 微電子晶片防偽
10. 微電子身份驗證系統

物理學在防偽印刷技術上的廣泛應用

- 防偽印刷技術涉及的科學領域很多，例如光學、化學、電磁學、計算機技術、光譜技術、印刷技術、圖紋字碼技術等，屬於一門交叉邊緣科學。
- 防偽印刷技術的研發主要集中在各種証券及商品商標等領域的研究、開發和應用。主要在以下六個方面：
 1. 紙張防偽
 2. 浮水印紙
 3. 安全線
 4. 防偽嵌入物
 5. 超薄紙
 6. 電子浮水印紙

折光潛影

- 折光潛影：運用凹印的暗影技術，利用橫豎不同的凹印線條對光傾斜效應的不同，在紙張同一部位製成兩種圖文。
- 當把這種圖文對著光源平視時，見有一種圖文，根據設計，如把紙張水平旋轉45度或90度時會變換成另一種圖文。
- 加拿大、瑞典、捷克等國的護照上已使用了這一技術。
- 台幣、美金、港幣、人民幣的紙鈔和金屬錢幣上亦已運用此技術，作為防偽設計。

2000元

100元

200元

500元

1000元

秘訣一：水印

迎光透視



可見「松樹」、「2000」水印



可見「梅花」、「100」水印



可見「蘭花」、「200」水印



可見「竹子」、「500」水印



可見「菊花」、「1000」水印



秘訣二：變色油墨

輕轉鈔券



「2000」由金色變綠色



「100」由紫紅色變綠色



「200」由金色變綠色



「500」由紫紅色變綠色



「1000」由金色變綠色



秘訣三：變色窗式安全線

輕轉鈔券



安全線由紫色變綠色，並有「2000」字樣



安全線由紫色變綠色，並有「100」字樣

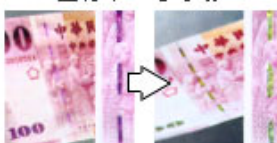

安全線由紫色變綠色，並有「200」字樣

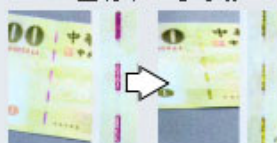

安全線由紫色變綠色，並有「500」字樣



安全線由紫色變綠色，並有「1000」字樣

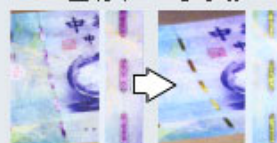

秘訣四：隱藏字

以15度角側面檢視



鈔券右下圖紋中浮現「2000」字樣



鈔券右下圖紋中浮現「100」字樣



鈔券右下圖紋中浮現「200」字樣



鈔券右下圖紋中浮現「500」字樣



鈔券右下圖紋中浮現「1000」字樣



2000元新增防偽功能

輕轉鈔券



「2000」字樣及「衛星」圖案呈現漸次閃動、不同顏色之變化。



秘訣六：金屬油墨加印「2000」字樣

輕轉鈔券



「火箭」圖案兩側呈現金屬光澤



經掃瞄影印後，顏色變化差異大，「2000」字樣不清楚

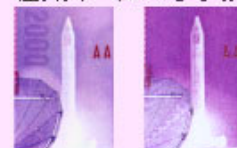

秘訣一：幣邊滾字



50元

共有四段「NT\$500」字樣，呈正、反順序排列在幣邊中間。

秘訣二：防偽隱藏圖案



向左、右各轉15度角檢視，可清楚浮現「𠄎」及「50」字樣。

秘訣三：盲人點



有清楚之凸點，可供官胞與弱視者觸摸辨識之用。

新版台幣鈔券辨識秘訣

新版台幣鈔券辨識秘訣

新台幣防偽說明圖



目前除了「連續隱藏字」之外其他各項防偽都已經遭到破解，所以辨識隱藏字是避免收到偽鈔的最佳方法。

3D立體驗鈔卡

- 將顯像卡置於鈔票正面右下角浮水印地方 (顯像卡條紋朝上, 平面朝下)
- 顯示100、200、500、1000、2000數字即是真鈔
- 無顯示任何數字即是假鈔
- 如果未顯現數字請將驗鈔卡換個方向再試, 如還是未顯示, 則表示該張紙鈔為偽鈔

⇒快速又方便!



3D立體驗鈔卡--利用3D立體顯像原理

能快速、安全地辨識出新台幣鈔的真偽，可將防偽功能中所隱藏的字體部份顯示出來。

將驗鈔卡光滑面向下，放置於鈔票之隱藏字上稍微用力將紙鈔壓平，就會顯示被隱藏的數字。使用簡單，攜帶方便。

無驗鈔卡協助觀測時，無法顯現幣值的阿拉伯數字。

需以約5°的視角才能勉強觀測到。



紙幣上壓有驗鈔卡時，則阿拉伯數字的幣值便可以一般的視角輕易地觀測到。

- 亦可驗人民幣、港幣和美金。



旋轉吧！紙陀螺！將黑白變七彩！

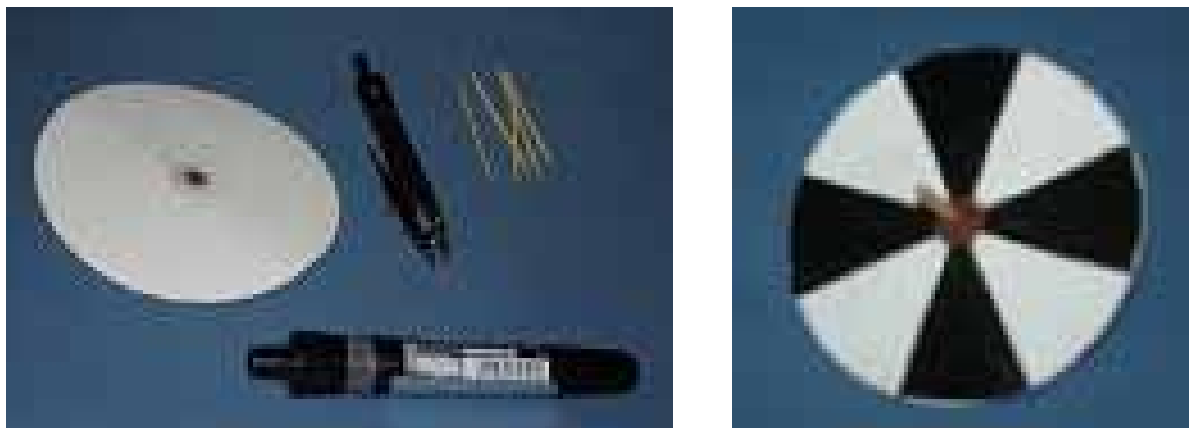

簡介：

利用偏光板特性，在兩片偏光板間夾著可透光的物質(膠帶)，在厚薄程度不同情況下，就有彩色的情況產生。在投影片上貼上膠帶，也可以先畫出圖形在貼，注意貼成厚薄不一，在夾在兩片偏光板間，面光可以看出彩色的圖形。(材料：厚紙版，還有一隻牙籤、圓規、黑色奇異筆。)

操作：

- (1)把厚紙版裁成圓形，並將此圓形分成四等份(幾等份隨便你)
- (2)個別在上面塗上黑色間隔
- (3)把牙籤紮入圓心，必要時用白膠固定中心，即製作完成。
- (4)旋轉陀螺。

原理：會發生色彩的原因

因光波的波長 λ ；日光燈是利用交流電游離燈管中的汞蒸氣，汞離子打到日光燈管所塗螢光粉層，使螢光粉發光，所以基本上使用60Hz是一秒中閃60次(交流電源所供應的頻率)，但因人的視覺暫留，所以覺得一直亮的。

在使用黑白陀螺或風扇的葉片貼上白紙，就是要和交流電同步：若一半黑一半白陀螺轉速每秒60轉時(或倍數)，你對著陀螺某一點看，若是白色又是日光燈管正在閃光時，就可以看到光，若不是此條件就看不到光。

而不同螢光粉會發出不同 λ 色的光，但同時受汞離子打到時，不同種螢光粉除了發光 λ ；色不同外，被汞離子打到後會延遲不同的時間後發光，因 \therefore 用黑白陀螺可和某 \therefore 色螢光粉發光時間同步(對某一點)，而只看到那個 \therefore 色的光(對某一點)。所以整體就成了彩色的。

若將一半黑一半白陀螺改 \therefore 黑白黑白四段(如BMW標誌)，則只要陀螺轉速每秒30轉(或倍數)就可以了，同理黑白六段轉速每秒20轉(或倍數)就可以了。因 \therefore 用手轉陀螺，陀螺由快而慢，到轉速合乎條件就會變彩色。

Euler's disk

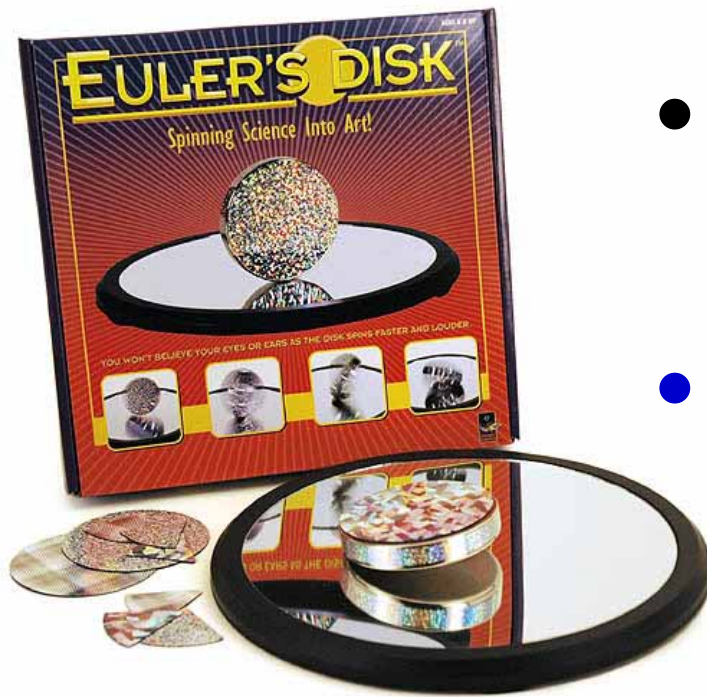

- The disk is a chrome-plated steel disk with nine pieces of magnetized holographic foil.
- A concave mirror base is the setting for the disk to spin like a coin—except it seems like it will never stop!!
- Just give it a spin and gravity does the rest!!

Operation:

- Observing the images and sound as the disk spins faster and louder.
- Want an increased visual effect? Shine a flashlight on the disk while it is spinning in a darkened room!



Plasma Sphere

隔空點燈

七、能源篇

- 太陽能發電
- 風力發電
- 太陽能與風力混合發電
- 氫燃料電池
- 火力發電模型
- V8引擎模型

Hydrogen Fuel Car- H Racer



The smallest hydrogen fuel cell car in the world!

Solar panel

Hydrogen Storage Station

Racing Car

Hydrogen Fuel Cell

The car uses a real fuel cell and its own on-board hydrogen storage system. It does not need batteries! The Hydrogen Station will provide the H-racer with an unlimited supply of clean energy.

To create free hydrogen fuel at the flick of a switch, just add water to the station's tank! Fueling is animated by a special blue light display.

- The **H-racer** is a futuristic toy car that contains one of the most exciting and advanced technologies of the 21st century. This car operates on 100% clean fuel produced by a miniature solar-powered hydrogen refueling station that converts water to hydrogen using energy captured from the sun.
- Cars running on clean and renewable fuel are the dream of many of today's world leaders, engineers and scientists seeking to eliminate mankind's reliance on fossil fuels in favor of climate friendly energy resources.

- With new advances in technology, hydrogen is on its way to becoming the world's next fuel. Hydrogen offers many important advantages: it is non-toxic, renewable, clean to use, and the most abundant element in our universe. And by using fuel cell technology to convert hydrogen to electricity without any combustion, the technology is a significant solution to many of our global energy and environmental problem.
- No combustion occurs inside a fuel cell. The only exhaust resulting from hydrogen fuel cell cars is pure water. Fuel cell cars that use hydrogen as a fuel are also known as “zero emission vehicles.”
- Today, many of the world's automotive companies including Toyota, GM, Ford, Honda, and Daimler-Chrysler, are developing hydrogen fuel cell vehicles with the hope of introducing this technology to the public in the near future.
- The **H-racer** is the working miniature version of what is being developed in real-size cars of the future.
- This palm-size fuel cell car contains an onboard hydrogen storage tank, a fuel cell system connected to the car's electric motor, and a hydrogen refueling system linking the car's storage tank to an external hydrogen refueling station.
- Given its small size, the **H-racer** is also very safe as only tiny quantities of hydrogen are sufficient to power the car.

